

COUNTING IN CYCLES

Karl Javorszky

Abstract: *Counting in terms of cycles allows modeling many processes of Nature. We make use of a slight numerical incongruence within the numbering system to find a translational mechanism which connects **sequential** ↔ **commutative** properties of assemblies. The algorithms allow picturing the logical syntax Nature uses when reading the DNA.*

Ordering a collection on two different properties of its members will impose two differing sequences on the members. The coordinates of a point on a plane of which the axes are the two sorting orders sidestep the logical contradiction arising from the different linear assignments. During a reorder, elements aggregate into cycles. Using an etalon collection of simple logical symbols (which are pairs of natural numbers), which we reorder, we see typical movement patterns along the path of the string of elements that are members of the same cycle. We split the {value, position} descriptions of a natural number and observe the places the unit occupies at specific instances of time among its peers, while being a member of a cycle, under different orders prevailing. Which places elements occupy among their peers, under specific order conditions, is determined by numeric properties of the natural numbers that make up the element. The model presented is therefore tautologic, and can be compared to a hybrid of sudokus with the ultimate form of Rubik's cube. It is necessary for the reader to do some self-education on the matter of cycles as a prerequisite to understanding the working principle of the model. The contraption being a new development, it can't have references in literature.

One cannot lose a bet on the idea that sorting and ordering a collection of elementary logical elements will turn up typical patterns and that these archetypes of patterns will be of interest to Theoretical Physics, Chemistry, Biology, Information Theory, and some other fields, too.

Keywords: *Information, fundamental definitions of; memory; learning; AI; enumerations of states of sets.*

ITHEA Keywords: *F.4.1, H.2.4, I, I.2.11, I.6.5, H.1, I.4.8, J.3, A.1, H.3.3, E.1, D.2.2, C.2.4, I.5.1, D.2, A.0*

DOI: <https://doi.org/10.54521/ijita29-01-p02>

Overview

We offer an answer to a question that relates to the basic problem of theoretical genetics: *how, by which methods does the information contained in a sequence – the DNA – get translated into information contained in a commutative assembly, the organism?*

We show the accounting that bridges the differences between two ways of assigning symbols to logical elements. In the assembly containing contemporary elements, we deal with *groups*, in the assembly containing sequenced elements, we deal with *sequences*. The property of belonging to a group is simultaneously valid for all members of the group: we see the members of the group sharing a commutative symbol. The property of belonging to a sequence assigns neighborhood relations to the members of the sequence, designating a predecessor and a successor to each of the elements.

The decision to read off the symbols from members of an assembly with regard to their similarity or rather with regard to their diversity resides with, is done by the human spectator who observes the assembly with the symbols its members carry. Like beauty, it is in the eyes of the spectator, whether he recognizes in the assembly sequences or rather commutative groups. Nature apparently does not maintain this human-made dichotomy: the organism can as well be described by the sequence of the logical tokens in the DNA, and as well by the physico-chemical, physiological attributes of the constituents of the evolved, unfolded collection of cells that are in their contemporaneous whole the same organism which its DNA describes. We have a collection that Nature reads once reading logical tokens in a sequential syntax, once in a syntax that combines properties of concurrently existing logical tokens.

The surprise is that this accounting linkage is indeed possible. There is a slight combinatorial incongruence in a specific region of **N**, which allows for accounting translations between number of objects, and number or kinds of logical relations. (See: www.oeis.org/A242615) [4]

Finding a slight **inner incongruence within the numbering system** brings forth questions of a fundamental nature:

1. How does a logical system function if it contains logical contradictions, even if the contradictions remain local and mostly navigable?
2. Does Nature utilize the extents of incongruences as entries in her accounting?
3. Does the existence of an inner deviation in readings of an assembly once temporally transversally, once temporally longitudinally, allow for units of discongruence to exist, be additive and carry a meaning?
4. Is there a quasi-stable, or ideal, collection of states the assembly can remain in, while adapting to and working with periodic changes, utilizing the instances of realizations of incongruence?

Using an **etalon collection** of logical tokens, we show factual truths of a numerical nature which allow conceptualizing an interdependence between being sequenced and being commutative. The numerical facts give rise to geometrical constructs of planes and spaces. The model proposed is a collection of symbols which are sorted, resorted, ordered, and reordered in consequence of **periodic changes** the existence of which is considered axiomatic. During reorders, **cycles** appear. Cycles are the core theme of this essay. We suggest a self-experiment, with about a dozen of books which one sorts and resorts, to convey the central idea of cycles by means of a deictic definition. The reader needs to work through a self-education exercise, of which we provide an example, to understand the subject this treatise explicates. Like it is unavoidable to actually attempt to solve a simplified sudoku, and it is unavoidable to actually attempt to solve the Rubik cube, in order to understand the working principles behind these educative entertainment tools, it is unavoidable to do the necessary educational steps in order to be able to comprehend the principles behind the algorithms presented here. The reader needs to order and reorder a few different objects, say a dozen of books, before

they can understand that **stationery objects** and **transitory objects** belong to **different logical categories**.

Splitting the $\{value, position\}$ description of a natural number we establish diverse positions for the same unit, situated among its peers, in dependence of orders presently prevailing and changing periodically. The $\{value, position\}$ readings of a symbol refer to the $\{linear\ rank\ on\ \mathbf{N},\ coordinates\ of\ a\ place\ on\ plane\ \mathbf{N} \times \mathbf{N}\}$ attributes of the symbol. The etalon collection is a table listing all possible ways for a whole to be consisting of two parts. There appear typical movement patterns when the collection undergoes periodic changes. **One will not recognize the movement patterns of elements of an assembly undergoing a reorder until one has learnt what happens in detail during a reorder.**

One cannot lose a bet on the idea that sorting and ordering a collection of elementary logical elements will turn up typical patterns and that these archetypes of patterns will be of interest to Theoretical Physics, Chemistry, Biology, Information Theory, and some other fields, too.

1. Introduction

High aims, backbone algorithm

The present treatise goes into details regarding relations among symbols. It is in some respects a continuation of Wittgenstein's *Tractatus Logico-philosophicus*. [1] In that work, relations among concepts that are imbedded in a *static* world were brought in a systematism. Here, we deal with concepts that are consequences of *changes*: we discuss the inner workings of a logical system that undergoes periodic changes. We offer a Treatise about a Periodic World.

Like in the *Tractatus*, we also orient our ideas about right and wrong on formalizing the statement and translating its contents into such words which have a defined meaning. By translating particularities of symbols into generalities of symbols, relating each idea to a natural number, we are able to ascertain the truth of the expression by conducting simple operations based on

N. We use the same logic Wittgenstein used, demonstrated on $(2+3=5: .true.;$
 $3+4=6: .false.)$.

We have added to the *value* meaning of a natural number a *positional* meaning for the natural number, taking into consideration the order context surrounding that natural number being situated among its peers. The relative position of a symbol among its peers is determined, in the classical, linear way of dealing with natural numbers, by its value and by nothing else. In extending the traditional approach, we observe each member of a collection as an individual and register, **where** it is situated in **different order contexts**.

One structural drawback of the Sumerian-developed counting system is that it traditionally de-individualizes the logical elements contained in a collection. In the **value-only** approach currently generally in use, the properties of an element are given by the number of identical basic units of *1 (one)* needed to make up that extent of units which the value of the number represents. In the **value-in-context** approach we introduce here, the symbols are much more differentiated than being *n* times the extent of *1*. Lacking established units of individuality, an *etalon collection* of individuals has been developed, by pairing natural numbers. We use pairs (a,b) of natural numbers. They come in cohorts. If there are *d* varieties of a,b then the cohort will consist of $n=d(d+1)/2$ simple logical elements.

We sort and order this etalon collection of simple logical symbols. During the reorders from one linear order into a different linear order, we encounter *cycles*. **Cycles are the core theme of this treatise.** Cycles create space webs and opportunities for coexistence together with cost/benefit analyses and results of negating the coexistence for the logical elements.

Our pairs – who were given the name ‘*logical primitives*’ after M. Abundis [2] – are each concurrently a logical statement about a thing that consists of two parts. The etalon collection is concurrently a catalogue about the ways of how one thing can be containing two parts resp. how two things can create a joint third thing or transform into being that third thing. The cycles are implications of properties of natural numbers. The **cycles exist a-priori**, apparently also in Nature, too.

We reiterate the ancient belief of the Pythagorean tradition [9] that relations among numbers are the basis for the Laws of Nature. To give credence to this belief, we shall enumerate some points where theory of logical sentences and practical observations of reality are in congruence.

The cultural impact of the invention

A specter is haunting the technical sciences – the specter of *biological mathematics*. The task of accommodating the changing varieties found in biology into the landscape of classical mathematics is a complicated endeavor. Modeling the self-referencing and self-regulating interdependencies common in biology is constrained by many rules of thinking which do not foresee the flexibility of a system full of variants.

In part, there are cultural reasons for the difficulties of developing a biological mathematic. We have grown up with convincingly practical ideas we inherited from the Sumerians, based on one basic unit, of which we use aggregated multiples as symbols. The system is impeccable in its inner consistence: no contradictions, no special numbers, unified and with parts that are seamlessly fitting.

Imagine now that we are in the cultural situation of society at Galilei’s time. The Earth centered world view is being accepted, by tradition, as the correct system of understanding the relations among the Earth and heavenly bodies. The system of concepts that worked as fundamentals and web of a geocentric world view was congruent within itself.

Reality has challenged that model of the world. Galilei was a proponent of an upgraded world view, with a heliocentric concept, in which the Earth was dethroned of its importance as the center of the world and became but a planet. The proof of his ideas was his exactitude in predicting observational results on the moons of Jupiter. We see moons circling Jupiter: these moons do not circle Earth: geocentric model of the world is invalidated. It was not the **fact** of moons circling a planet, it was the **implications of the fact** that brought him into hot water.

In our days, the experiment that leads to the *invalidation of a central concept* of society uses no telescopes, but rather computers, to find factual arguments comparably persuasive to moons circling a planet. We point not to moons but to patterns of movements among elementary logical tokens when these undergo periodic changes. The **fact** of there existing typical patterns of manifold interrelations among members of an assembly of natural numbers is beyond dispute, just like the **fact** of the moons was acknowledged to be reality. The **implications of the fact** are communicated within society according to the permeability and thirst towards new world views; these determine, how a new observation and its implications become culturally accepted.

Applicability of the results of the present work in applied sciences

This text is a logical treatise. It deals with the grammar of the logical language. The grammar of the logical language delineates the concepts that can be expressed interpersonally against such concepts that are not understandable. The delineation happens by exclusion and by inclusion. There is a bias in current thinking by assigning a *false positive* attribute in exclusion and a *false negative* in the inclusion process.

Exclusion: Two well-established rules of logic currently used inhibit in their combination the immediate understanding of the contents of the present treatise:

- 1) Anonymous objects can be lined up in any ways; one will not notice a different sequence among the objects, because these are indistinguishable.
- 2) The basic unit we use is an embodiment of the *thing as such*, (*thing in itself*) [11], devoid of any properties above being *one* unit: the basic units are anonymous.

Conclusio: Different sequences realized on elementary units of our thinking cannot be distinguished.

Inclusion: Observable are such differences among sequences in which the elements are distinguishable.

- 1) Symbols that distinguish elements are assigned to the elements by us, humans; units as such have no discriminating symbols immanent to them.
- 2) We can only discuss differences among sequences into the elements of which we had assigned distinguishing symbols; we have not done so yet, and the elements as such have no distinguishing properties.

Conclusio: Not having assigned distinguishing symbols to elements of a collection, we have no way to observe differences among sequences realized on the collection.

We present in this treatise a collection of algorithms which establish relations between the elements of the collection. This is made possible by creating an etalon collection of logical sentences which is based on and supported by the fact that the elements of our collection have individualities. We simply create the numeric realizations of the logical sentence $a+b=c$ for the first few a, b . Now we have the key to unlock the grammatical blockage hindering us from observing differences among sequences the members of the collection can be ordered in.

The grammatical rules of our current thinking say: We are not in a position to discuss sequences of elements of a collection based on immanent properties of elements of the collection, because the assumption of immanent distinguishing properties of elementary units is currently judged agrammatical. If elementary logical symbols are considered to have no innate, immanent distinguishing properties, it is agrammatical to talk about different sequences observed by differing orderings of the assembly, based on innate, immanent distinguishing properties of the elements, because in the present grammar the possibility is not foreseen for elementary logical symbols to have innate, immanent distinguishing properties.

We overcome the restriction of perceiving observations. The rhetoric and didactic is the same as persuading someone, a person X, that A is indeed, in fact, really, actually true, and is the case, even if person X states that A is not foreseen by the ancient teachings, and A is not supposed to be the case, because established teaching makes no mention of A being allowed to be observed. It has moreover been decided that A cannot be observed, because

there is no such thing that would make possible to observe A. As symbols have no a-priori meaning, any sequences among symbols can only have been made by our own work, and the results of observing the effects of our own acts are trivial, being consequences of our own work. All permutations are man-made, says objection. **I answer that** [12]: There are some facts of Nature that share the appearance with permutations. Sequences based on properties of natural numbers may look like permutations and may be elements of the collection of permutations, based on formal descriptions that apply to these. Yet, there exists a separate (*sub*)class of permutations that are not man-made but reflect a-priori existing logical-numerical relations between elementary (but composite) logical units.

Now we approach person X and demonstrate that A is the case. We have indeed violated, disregarded, hurt, and negated some grammatical rules by pointing out that elements in our self-made etalon collection do possess innate, immanent distinguishing properties. These properties of the members of our etalon collection are implications of properties of natural numbers.

Using this tool, an etalon collection of realizations of $a+b=c$, we propose to create a mental concept that relates symbols of logical sentences to mental pictures of Nature which are shown to us by the applied Sciences. Taken Biology as an example, we propose the following chain of reasoning (*see Table 1*) to connect abstract symbols to results coming out of observations of measurement instruments:

Table 1: Steps of reasoning

Step	Create concept	Use concept	Implied concept
1	Rank in linear sequence	Line up elements	
2	2 ranks in 2 orders	Planar position	
3	Cycles	Members of a cycle are both <i>sequentially ordered</i> and as well	Periodic changes

		share a <i>commutative symbol</i>	
4	Spaces	Assemble 2 Descartes type spaces woven by cycles	Gravity, electro-magnetic fields
5	Paths	Draw pictures of the strings	Matter in transit, types of strings
6	Agglomerations	Calculate <i>types</i> of pileups where paths of strings cross	Chemical elements
7	Economics of physics	Establish neutral range and under-, overdensities	Molecules
8	Feedback tautology	Places on planes and positions in spaces	DNA syntax
9	Alternatives and information	Predictability of next step	Information as a numeric value

Overcoming the *false negative* delineation which eliminates results from observing sequence differences within assemblies is easily achieved by assigning individualities to the elements. If the assignment happens in the *most fundamental fashion possible*, by using natural numbers as arguments of the sentence $a+b=c$, **the resulting system of relations is very robust**. Nature herself draws a space web and places the transient objects into this web – as far as natural numbers are a product of Nature.

We see the web of logical statements that is dictated by the natural numbers to consist of idealized points on planes, which planes are assembling in spaces. The simple model presented here idealizes into the **dichotomy: objects are on their places vs. objects are in transit.**

The didactic aspect of the present work

The present work is an essay which tries to straddle the divide between speaking about facts and speaking about implications of the facts. It is not necessary to go into great detail regarding the moons, (here: tables built up on properties of natural numbers), because one who is interested more than superficially, will use one's own telescope (here: computer). The novelty we introduce is that of **keeping counting while sorting and resorting.** We propose accounting for and categorizing the replacements that are the unit of a periodic change. We go into the details of place changes and create a **web of places as such**, into which we position the transient objects.

The essay gives an overview *first* of the implications and *then* presents the facts. After the Introduction, chapter Relevance suggests some fields in which the so-called ordometric counting can presumably advance ongoing research. The most important part of the work is the **central chapter of Self-experiment.** The reader is invited and strongly encouraged to practice the fundamental concept, that of **cycles.** The best credibility to an idea comes from handling physical objects with one's own hands. *We invite the reader to line up a dozen of books and reorder these on their table*, such actively experiencing the concept of cycles. On an example collection we give step-by-step instructions on how to establish the idea of a cycle. The **self-education is necessary**, because the model created by ordering a collection of logical tokens, each an individual, is comparable to a *mother of all hybrids of Sudokus and Rubik cubes.* After having done the necessary self-education, the reader is invited to reread the chapter Relevance. The chapter Etalon Collection presents the interacting parts of the model, chapters Patterns and Interpretation discuss the implications of facts of interactions among cycles. In chapter Information we offer approaches to definitions of the term, among these, two arbitrarily chosen cycles as etalon patterns from which numeric-deictic definitions of information can be read off. The work closes by a Resume.

2. Relevance

In the following sections some points are raised which should give a credibility to the idea that a new way of counting will have practical benefits in the didactics of understanding some phenomena of Nature.

2.1. Memory

We possess the ability to remember a previous situation. At both the times of registering and of recalling the content, two systems of the brain interact. The thinking part communicates by means of electric bursts, the experiencing part is a complex biochemical mixture in which the pattern of electrical discharges is integrated, like patterns of lightning typical for a landscape.

The two ways of expressing information are syntactically different. In one case, the units of discharges are quite *uniform*; the distinguishing pattern lies in the *distance* in time between two discharges. In the other case, the biochemical-hormonal carrier substance has no temporal distance between its elements, which are contemporary. The contemporary symbols are in their properties *manifold*.

The pattern of discharges – the thoughts – are representative of the biochemical mixture (our neurological – physiological state), that embeds and supports it, from below-inside; it can moreover alter the composition of the mixture. We can influence our feelings by means of our thoughts. The thoughts interact with the feelings; the feelings are the carrier substance of the thoughts.

There exists a translation mechanism between language A that speaks by distances between uniform words and language B that speaks by variants of contemporaneous diversities of assemblies.

2.2. Learning

Learning is based on the increase of the proportion of hits among hits and misses of a repetitive procedure with possibilities to conduct trial and error experiences. First, alternatives among the stimuli need to be established, (remembered), the reactions to which can then be evaluated. Learning is a pattern recognition exercise. A pattern is a sequence of symbols which allows regularly predicting the next symbol of the sequence. *Periodic changes* are the

basis of learning because adaptation to predictable changes in the environment is an advantage in evolution. How much are periodic changes predictable? Life on Earth has had to learn to adapt to tides, day/night and yearly periodicities. Having learnt successfully means being ordered for the new task. Learning is reordering.

2.3. Genetic

The same information theoretical problem like in the case of the memory, we encounter in the field of theoretical genetics, too. In the former we see one method of information containment in a sequenced form, in the bursts of the ganglia. What was in that context microsecond, is here the DNA with its numbered sequential positions. Both sequences interact with a fluid environment: in the brain with the nutrients and hormones present in the physiology, in genetic with the flesh-and-blood organism, which is also definitely not sequential, because all its elements exist contemporaneously.

The translation language is based on movement patterns of logical symbols during reordering. The movements happen in units of three turns. One word in this logical language consists of three directed turns of a rectangular Descartes space. On each of the turns, one of four logical markers can be present. The markers determine which geometry is applicable in two Euclid subspaces of the common space. This syntax gives us the logical structure of the DNA.

The specificities and particularities that are transmitted by the DNA are understood to be identifications of geometric variants of possible sub-spaces being contained in a sequenced series of phase-turns of three sequenced steps each. The specificities of the subspace delineate such molecules that can attach in this *and in the next* geometry against such which have no fitting geometrical representation in the *next* plane in the process of continual turns in three spatial dimensions which are created by twice three planes with 3 and 3 respectively common axes, which create two Descartes-type spaces. Three turns make up one logical-temporal-spatial unit.

2.4. Predictions

The concept of this self-regulating system relies on the existence of locally and globally existing linear enumerations. We assume the existence of clocks and therefore of ticks. The picture of three spatial turns that constitute one moment fits well with a concept of time that is circular; in which many closed loops co-resonate. We shall detail how certitude evolves as more and more signs predict the correct guess as we discuss which elements of cycles that run parallel will appear periodically contemporaneously. If something occurs periodically, how many predictors are needed so that one can be certain about the next step in the periodic process? The foreboding signs are members preceding and succeeding each other within a cycle. Learning is an improvement in foretelling. The hypothesized underlying mechanism of interactions in a multitude of symbols, on which we do the foretelling, is apparently a gift of Nature to all animals that can learn. The mechanism that enables learning is an information theoretical marvel. The general rules of learning will follow one basic engineering form to learn on, with cycles that run predictably within periodic changes. The information compression into the memory happens by utilizing the offset variants of one and the same context-cycle.

We are adapted to periodic changes. During such, biochemical reorders happen. In the example of sleep, cleaning up, eliminating waste, and recharging the constituents of the system happens during a reversal of priorities, a reorder. The main idea is that both the whole of the process, the sleep, and its lower level sub-processes also, are subject to a linear enumeration; that is: *there exists a clock concept for the overall process* and several local clocks which regulate a more elementary process of reorder (like one breathing cycle, one heartbeat or one unit of intercellular biochemical process). The Zen concept of a world which is based on many closed loops is flesh on the bones of ordometrical relations. [3]

2.5. Theoretical Physics

The sentence $a+b=c$ describes a scene in which 3 actors are present. These each have their own world. In our elementary schools, following the Sumerian tradition, we declare and pretend that as long as the values agree, all is well

and keep on going, there is nothing to see here. This is a **heavily sanitized, family-friendly version**, for children’s brains evolutionary stage, of what tragicomedies of rivalry, competition and conflicts go on, alongside tenuous compromises, in logical reality, between a, b, c in the background.

By sequencing our logical primitives in two different sequencing orders, we create a plane. Each element has a place on a plane defined by its respective linear positions in two different sequences (see Figure 1).

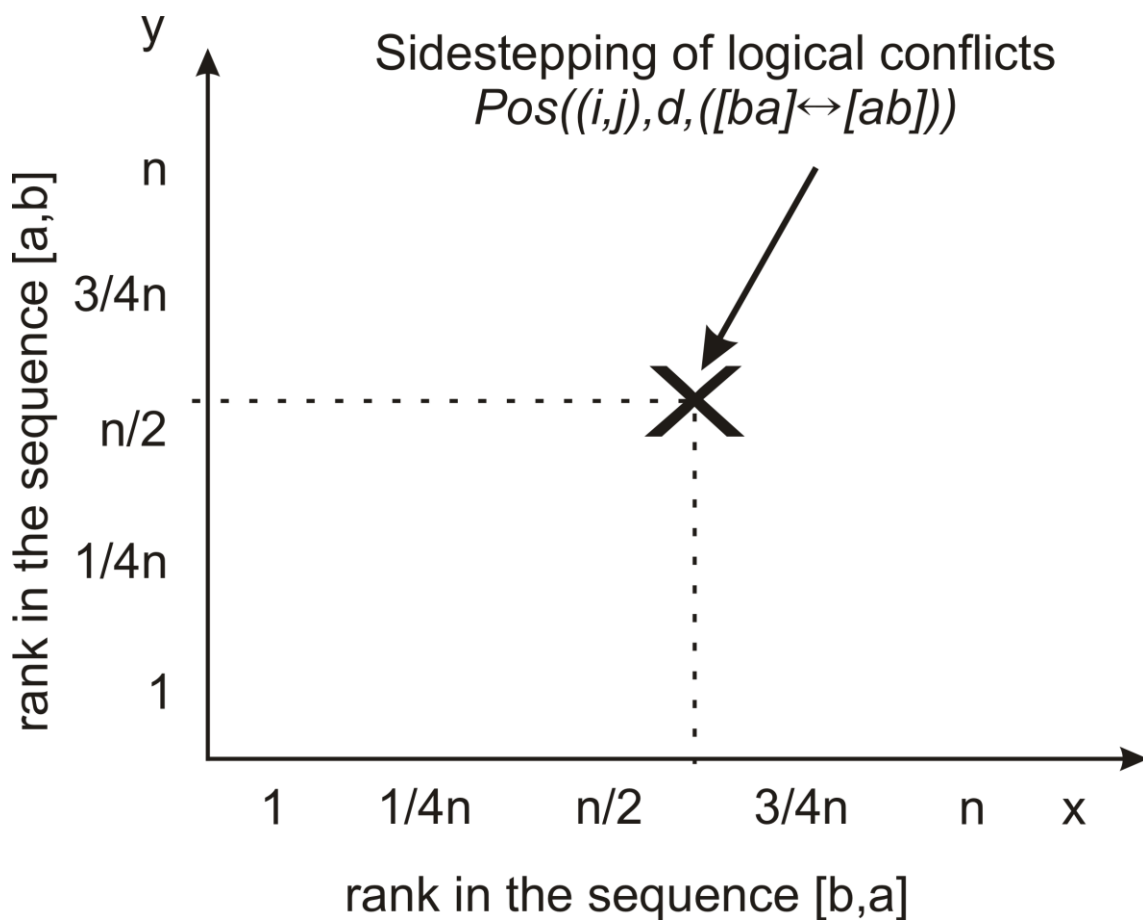

Figure 1: Two sequential ranks determine one planar position

Reorders are based on **cycles**. The collection of its cycles is a reorder, by theoretical definition. How strict the practical requirements are, regarding the completion states of cycles that are the constituents of a reorder, so that we can

say: *this reorder is taking place now*, is dependent on many circumstances. We distinguish **standard reorders** and **non-standard reorders** (see Figure 2).

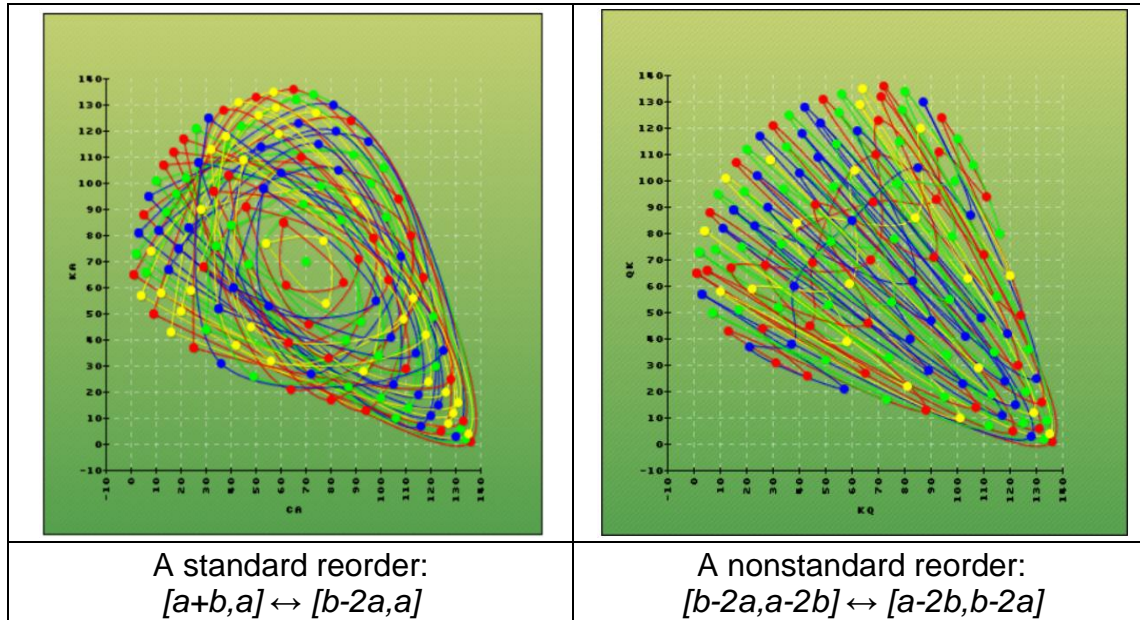

Fig. 2: Two examples of cycles in reorders

Suitable planes can be assembled, of the standard reorders, to create rectangular spaces which we call Euclid spaces. There are *two* Euclid spaces generated by ordering pairs of natural numbers.

The model offers a **basic duality**, based on different readings of $a+b=c$. The uniformity among the readings is that they all refer to measures of linear distances, which are expressed in identical units, in such fashion weaving a background structure of similarity in our perception of the world. The diversity among the readings comes from the fact, that a, b are by their setup possibly different. The *frequency, value* attributes of the symbol groups are different.

In both left and right Euclid spaces (see Figure 3a) one finds a **central element**. Their logical relations among their peers are identical, their numeric relations among their peers are different. The central elements serve also as a geometrical definition of a point. We reintroduce the concept of a point, without taking recourse to an axiom, by using ordometrical procedures, that is: simple sorting and ordering on pairs of natural numbers.

The two Euclid spaces are merged, as far as possible or convenient into one Newton space (see Figure 3b). The axes x, y, z of this space are, respectively: $b-2a, a-2b, a+b$.

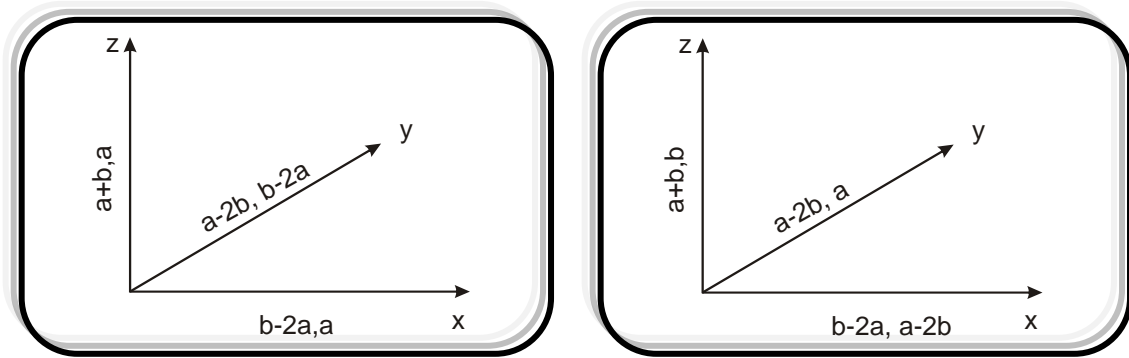

Fig. 3a Two Euclid spaces

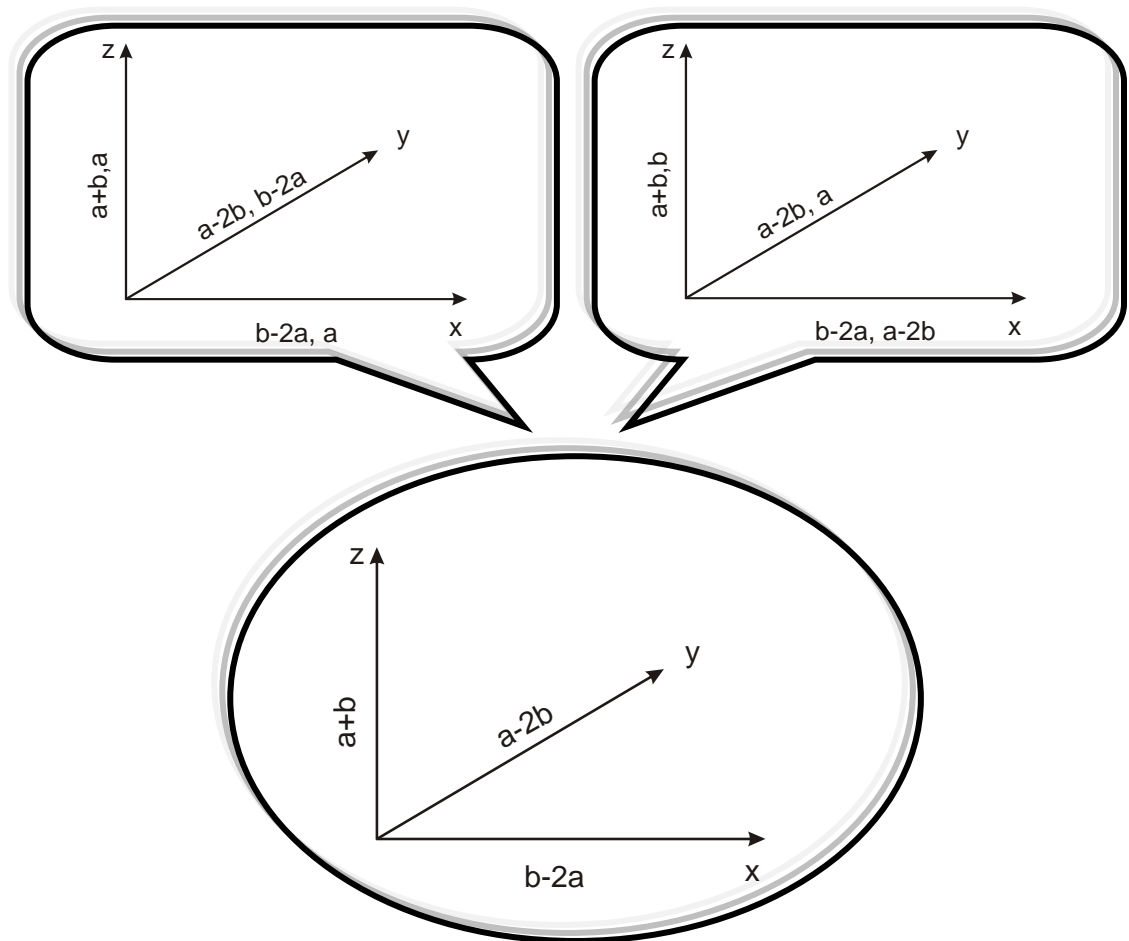

Fig. 3b: One Newton space

Fig. 3. Planes generate spaces

The axis $a+b$ is oriented and built of identical steps that are elements of \mathbf{N} . This basic feature of Nature gives meaning to the terms *up*, *down* we experience in the form of **gravity**. The interpersonally common experience of gravity has allowed the Sumerians to conceptualize \mathbf{N} , directed and made up of units equally distanced, each made up of multiples of one basic unit.

The two axes $b-2a$, $a-2b$ generate a **plane of diversity**. There is a charmingly archaic touch to the concept of measuring two somethings relative to each other by discussing how the double of my part would appear relative to your part, as opposed to how the double of your part would compare to my part. The basic antagonism between a , b is exacerbated and rhetorically enhanced by comparing one part to the double of the other part: this story is rendered twice, once under the viewpoint of a , once from the perspective of b . The cumulative measure of the diversities of the descriptions assigns a place on a plane. Members of cycles on this plane are in an equal extent diverse to their peers. One example for the idea that the axis of similarity is crossed by planes of diversity would be the rings of Saturn.

The reorder $[ab] \leftrightarrow [ba]$ is arguably the most archaic of reorders. (see Figure 4)

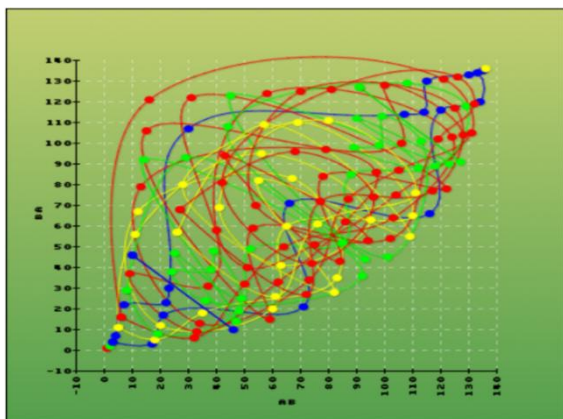

The important reorder $[a,b] \leftrightarrow [b,a]$ contains 12 cycles

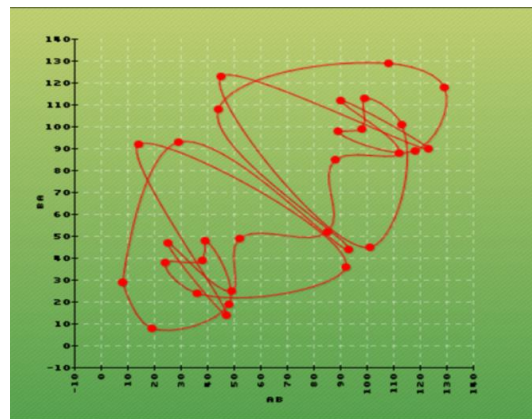

Among them, cycle Nr 6 presents archetypal biologic forms as numeric patterns.

Fig. 4: Reorder $[a,b] \leftrightarrow [b,a]$

Some of the non-spatial cycles can be pictured as strings or filaments. Some make rather the impression of foam. The idea of *quantum entanglement* is an assumed principle behind the observation, that objects that are not connected in any discernible ways, act as if they were connected by some mysterious lien. The idea of cycles includes the idea that the existence of a predecessor implicates the existence of a successor. The relative spatial distances between members of a cycle are but one of the properties of the cycle. The extent of predictability of the properties of successor members of the cycle can have diverse realizations. Maybe for some certainties resulting from being a member of a cycle, spatial distance is not extremely relevant. In the field of non-ordinary objects, the linkage among members of a cycle can be seen to come into observable existence exactly in that form as its theoretical form suggests it to be. The existence of predecessors can build up to a certainty about what properties a certain segment of space will have. It would be nice, would the quantum entanglements be pictured by patterns of the movements and coordination among the members of the etalon collection during reorders. One may hope that among the manifold numeric relations between *certitude* and *energy-potential-information-distance-position-value*, some will be found that match the measurements conducted with quantum entanglements.

The model shows an **increase in inner inexactitude** with $n \geq 135$, reaching a logical threshold at the double value 136, 137. The two values $n!$, $n^?$ (A000217, $\exp(\ln(A000041)^2)$), [7], [5] refer to the same threshold of inexactitude: One surveyor uses measuring rod A, the other surveyor uses measuring rod B. At a specific point both surveyors say: the difference between our measurements has now for the first time reached one whole unit. Up till now, the measurement consequences of differences between our rods were relatively minimal and correctable. Now rod A was used 137 times, while rod B was used only 136 times to reach this point. If we err among each other to the order of magnitude of one whole unit, the idea of cooperative measurements, yielding doubly true logical sentences, is no more supportable. There is a natural limit in existence on the number of doubly true relations a member can have to its peers: if the group grows too big, no counting of doubly true relations can take place. The findings reported in www.oeis.org/A242615 [4] could be of interest to someone

working on *Eddington's* [6] determination of the maximal number of theoretical objects that can interact at 136, which research has later shown to be slightly above 137.

Unavoidable agglomerations of units generate over-density at some places. Like in a map of traffic: if there is a *sufficient number* of participants steering to diverse goals, the creation of traffic jams is a certainty. The cycles are parts of reorders. Reorders impose movement patterns on members of the assembly. One may suggest that pileups are unavoidable. To the idea of a **multitude that is ordered in diverse aspects**, the idea that during such a process, at specific (typical) places, **types of agglomerations will appear**, is a deduction. The pileups come with the *logical* system and one can distinguish them among each other, (e.g., by how many cycles cross this place, what are the numeric characteristics of these cycles, etc.) and thereby create *types*, which exist a-priori, in an *archaic* fashion since ever, eternal like a logical truth, being a consequence of properties of natural numbers. The variants of the mental product ‘traffic jam, pileup, agglomeration’ should then be named **logical archetypes**. The **chemical elements** in their role as ordometrical constants would answer to the idea of logical archetypes.

There are **two planes transcending** both Euclid spaces and the common Newton space too. These two planes are independent of the actual existence of (any absolute extent of) size, as the twice two axes which create the two planes mix a , b , $b-a$ with $a-2b$, $b-2a$. (*The addition into $c=a+b$ needs not to be the case.*) The influence of the values on these planes on the movement patterns of archetypes is dependent on the type of the archetype. One may suggest investigating whether the two transcendent planes which affect only some classes of objects, can serve as an allegory for the principle of **electromagnetic fields**.

2.6. Molecular Geometry

The two Euclid subspaces are perceivable for the human spectator as movement patterns of logical primitives while undergoing some of the most basic transformations. The subspaces are spatial grids with axes $(a+b,a)$, $(b-2a,a)$, $(a-2b, b-2a)$ for the left subspace and $(a+b,b)$, $(a-2b,a)$, $(b-2a, a-2b)$ for

the right subspace (see Fig. 3a). These space-generating, “standard”, cycles are a class of their own. The standard cycles of a reorder contain 45 times each 3 of such elements that for each of the standard cycles holds true that $\sum(a_1, a_2, a_3) = 18$; $\sum(b_1, b_2, b_3) = 33$, the 136-th element having the values for (a, b) : (6, 11). The standard cycles create **Triads**, where the value of the 3rd element is a deduction and implication of the values of 2 elements being already known. There is an inbuilt stability in the system, which treats the *third* coordinate as a result of *two* given coordinates.

Each cycle has a reading that reflects on the spatial grid. Any element $\{\dots e_i \dots\}$ of a cycle is one specific pair of values (a, b) . This identification connects the logical primitive with two others of its peers, its partners in a **triad** (but for the central element, which is the embodiment of being average). The members of a non-standard cycle happen to be together during a reorder: this is a transient property. The member itself is bonded in a triad and this bondage is not transitory but eternal like a logical fact. With its temporal neighbors it is not sure that their *a-carry* adds up to 18. The members contribute towards the goal of reaching in their sum 18, resp. 33. The instances of being under- resp overvalued relative to the optimal spatial accommodation will invite name-giving conventions among scientists of the applied fields.

By brute force computing, one can establish the algorithms that sieve all possible cycles (and maybe later unordered processes, too) with respect of which expressions are true in both left and right subspaces. The standard cycles show us how space is generated. The non-standard cycles show us, how 3 consecutive members of cycles come near to the ideal as represented by the standard cycles. Apparently, there is a tolerance between ideal and actual values.

Reading the cycle in twos and in threes: The spatial reference each element carries with itself is a part of the properties of the element (is a part of the data depository that is an element). It refers to two other elements, with which this element would make up a standard cycle. The triad has the property $\sum a = 18$, $\sum b = 33$. The *third* member of the cycle has an expected spatial reference $a_3 = 18 - (a_1 + a_2)$. Reading the cycle *in twos* generates a sequence of shadow values accompanying the actual values read *in threes*. After *two whole turns* in the

Newton space (which take place concurrently), a dimensionless value remains which describes something close to the concept of the *momentum (dare I say increase in mass?)*, which comes from the difference in spatial references when reading in twos or in threes. (Counting the difference: $\sum a_i - (18 - (a_{i-2} + a_{i-1}))$) This amount can be carried over, inherited into the next physical-temporal-spatial moment of reading the next 3 turns into one unit, as long as the planes can stay interwoven.

Those expressions (cycles or parts of cycles) that can be represented in both ways of relating qualitative values to standard values (which are expressible in both left and right Euclid spaces): these can be represented in the common, encompassing Newton space too. To be able to be represented means that the succession of 3 members of the cycle do not deviate beyond the tolerance limit in their aggregated (a,b) values from the neutral values of 18, 33 respectively, which values designate **properties of the ideal space**. Spaces are mental constructs (in the reality of accounting, they are but assemblies of planes). The numeric structure is suitable to render a background picture of the landscape of our world view.

There is a requirement of **logical continuity** which needs to be maintained if the axiomatic periodic change is to continue. The left and the right subspaces differ not so much in their inner furniture but rather whether with which of the possible two axes to continue with. The common, Newton space is created by stripping the 2^{nd} argument from the search: $a+b,a; a+b,b$ simplifying the axis into $a+b$ (the procedure of dropping the respective second sorting criteria is the same for the other two axes). Therefore, every value on $a+b$ in the Newton space has *two* interpretations, once as coming from the left Euclid space, once as coming from the right Euclid space. The space does not influence which objects are situated in it: the space influences which of the logical objects have a continuation in the next turn. The two Euclid subspaces have different geometries, insofar as “being one of a predictable series of occurrences” is a geometric property.

A statement that refers to the position of a point in a 3D space has 4 possible interpretations as places on planes that are built by axes based on immanent properties of the elements (see Figure 5).

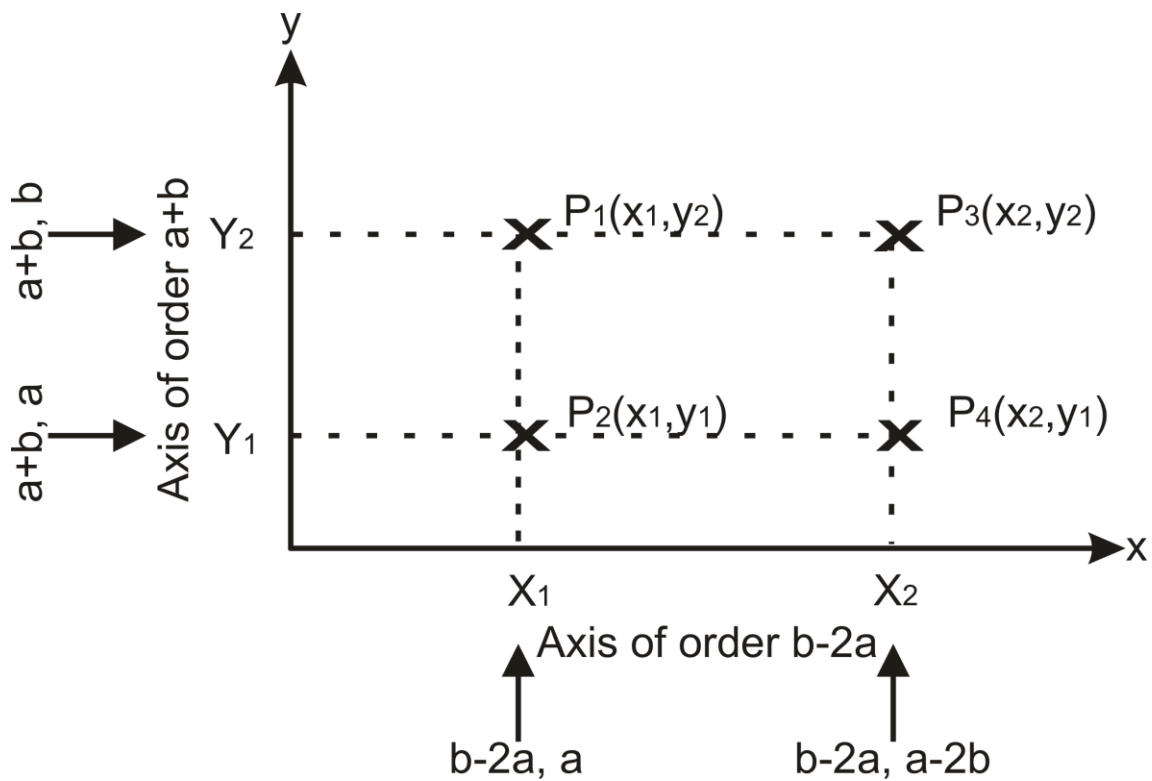

Fig. 5: Ambiguous spatial references

The inner predictability of periodic changes, here in their technical form as cycles, is what enforces coming into existence of that interpretation of a value (from among 4 possible variants) on c from $a+b=c$, the common Newton space, which continues in the sense of the change, maintaining a logical continuity.

2.7. Arithmetic

The proposed extensions and additions to the system of arithmetic will possibly lead to a debate, whether the procedures of **ordering and sorting** and their results belong inside or outside of the delineated domain of arithmetic.

Ordering and sorting are pre-mathematical dexterities of a human child. The neurological ability required is that of being able to discern differences in intensities or extents of impressions. The abstraction step of transforming the

object with the name a into an element of \mathbf{N} and comparing the value on \mathbf{N} with the value of \mathbf{N} arrived at by abstracting the properties of the object with the name b is not required as a neurological function. Ordering and sorting can be handled by the non-abstracting faculties of the brain. Parts of the brain that are phylogenetically earlier than the cortex, are by tradition considered to be more archaic and less versatile. We credit animals and even plants with being able to discern *intensity differences* while not yet being able to abstract detached concepts of the objects experienced to be different, much less using formal properties of extents of differences. In this view, ordomatic: the results generated by ordering elements, does not belong to the domain of arithmetic. Arithmetic is that what the cortex does, not that what older parts of the brain process, is the argument.

For the counterargument, we need to discuss **scales** that can be used to distinguish and to place elements. Below the *ordinal* scale is the *nominal* scale, above it is the *interval* scale (see Table 3).

In a *nominal* scale, the symbols are arbitrary and are used only for the reason of distinguishing elements (like the numbers on the tricots of a team of athletes). Nominal symbols do not confer linear ranks, as such, by their nature.

In an *ordinal* scale, the linear position of an element among its peers within a collection is established by a series of comparisons under one aspect of the collection. The symbols $\{<, =, >\}$ are based on /derive their meaning from/ properties of elements compared. We arrive at the general result (see Table 2), without reference to absolute values, in a linear context.

Table 2: Translation rule of values into linear positions

$a < b \rightarrow pos(a) < pos(b),$
$a = b \rightarrow pos(a) = pos(b),$
$a > b \rightarrow pos(a) > pos(b)$

The *interval scales* are the default assumption in use in technical sciences. There, the elements are not only placed along a line, but also, they stand at distances made up of equal intervals to each other. The distances are a connection to the *value* part of the description of a natural number. This is the concept of **N**.

Table 3: Scales and order among elements

Scale	Result
Nominal	Elements are <i>distinguishable</i>
Ordinal	Elements are <i>sequenced</i>
Interval	Elements are <i>equally spaced</i>

We propose to incorporate results from *ordinal scales* into the arithmetic conducted on *interval scales*. The proposed extension of the domain of what is arithmetic would include those cases also, where the relations do not go beyond the exactitude of Table 2. When we transfer the results of our calculations/measurements/observations to a more general variant-descendant of **N**, which we call **N_{ord}**, on which the ordinal relations hold true, but not necessarily the more exact relations of the interval scale, we run into ambiguities (*it is true that Mary is younger than Jane, but we do not know, by how much*), and combinations of expressions from the ordinal scale may even contradict some expectations based on the assumption of equal intervals. We are very much used to handling the interval scale and the interval scale exclusively, as the only tool in our shed. The counterargument states that Nature does not care at all, whether we use our fingers, computers, the thinking cortex or the feeling cerebellum during the process of creating for ourselves a picture of her doings. In this sense, the results from ordering individuals – ordometric results – do belong within the concept of arithmetic, because they

deal with relations among symbols, just with more tolerance and ambiguity towards the results.

Reflecting the two arguments one will bring forth a compromise view which regards the method of generating the universe of symbols. In arithmetic, one has a literally endless number of identical elements. In ordomatic, one has a limited number of members of a cohort of which the members are each an individual. Here, in the ordomatic context, we do not count **growth (of quantities)**, rather we count **densities (of qualities)** of relations among the members. The numbering system has foreseen the need to understand biology and has provided us with an accounting tool to translate different properties of the assembly into each other. We put to practical use a number-theoretical quirk, which works on the domain of **N** of $n \sim 66, \pm \sim 32$ wherein combinatorial results are slightly contradictory. The stage for the drama of creation, annihilation, attachment, and repulsion, etc. is set for a cohort of ideally 136 actors.

The main difference in technique which makes ordometry different to geometry, ordomatic to arithmetic, is in the **individuality of the elements**. We play with a relatively small collection of elements, but our elements have each a name and an individuality, with the drawback, that their *place* is indeterminate above being limited by two thresholds. We make chamber music with the symbols, not the marching music of a metronome along an endless number line, occupied by nameless heaps of elements distinguishable by the *place* they are on.

2.8. Logic

The present essay is a reformulation of Wittgenstein's main ideas, as expressed in the Tractatus. [1] We have many more technical tools at our disposal than were available 100 years ago. With the help of computers, it is possible to generate all true sentences that can refer to a context. Furthermore, one can alter aspects at will and occupy all possible perspectives from where to observe the multitude.

We have taken the sentence $a+b=c$ and have investigated all its possible forms, in cohorts in which the members can be different in up to 16 varieties. The collection of logical symbols we use is 136 strong and consists of one each of

the possible forms of pairs of (a,b) , like $\{(1,1),(1,2),(2,2),(1,3),\dots(16,16)\}$. These so-called **logical primitives** constitute our demonstration tool. The members are each a logical sentence stating that the state of the world is (a,b) . If we think a whole behind these two parts, it is easy to see that the sentences in their totality describe each of the possible variants for a whole to be in two parts. Whichever way whatever splits into two or fuses from two into one, the way is one of the elements of this **etalon collection**.

The members are possibilities. They aggregate into **cycles** during **reorders**. The existence of reorders is axiomatic; here we refer to the periodic changes that affect our habitat. The cycles appear to be newcomers in philosophical discussions. A cycle is a sequenced collection of elements sharing a commutative symbol. The reason for a specific element to be a member in a specific cycle during any given reorder lies in the properties of the two natural numbers that build up that element. The arrangements of the logical primitives into task cycles during a reorder exercise are given by numeric facts that are **a-priori**.

Using computers, we can in our days discuss that what is not the case alongside that what is the case. Our etalon collection has an inner coherence by the relations that are conferred from the numeric properties of the elements to the pairs, from the pairs to the cycles and by means of the cycles to the logical concept of order. In an ordered collection, the observation that X is the case allows predictions about Y, Z, ... that will follow, even though Y and Z are presently not the case. (Example: sunset. We can foretell, that soon it will be dark and cold, although presently neither is the case.) The cycles concurrently impose a reorder and are representatives of the reorder.

This treatise tries to explain conceptual links between the counting system presently in use and a counting system biology appears to be using. Its core question is: “How does information transfer function between sequenced and commutative forms?” With the cycles, we have found a **translation vehicle**, because the members of cycles are sequentially numbered among each other, although concepts of first/last are not evident, and concurrently they share a commutative symbol, namely that of belonging to this specific cycle during this specific reorder.

In the ideal cases discussed here, with memory and genetics, the system is well maintained and in optimal circumstances. The predictability is not influenced by random interferences. If one observes that X is the case, one can assume that X is a member of a cycle caused by reorder A. In this case, one can expect as next member to come in existence the element Y. If, however, X has appeared as harbinger of change-reorder B, in that cycle in which X is a member in reorder B, element Q would follow. This is the **transversal** incertitude. Once decided that reorder K is the case, of which X is a sign, one will expect D, E, F to happen. In our idealized case, there is no reason to count with this **frontal** incertitude, whether that what we predict to happen in k steps, will indeed happen or be disturbed by something unexpected.

If the predictability exists, conflicts are similarly predictable. One needs a logical tag for elements: “*will come into existence in k steps, taking part in cycle i of reorder W* ”. The implication of this property would be, that the element in question **does not exist** in the time slots $1 \dots k-1$. Notwithstanding it stating a nonexistence, the logical sentence does very well exist in many ways as much as those logical sentences that state a truth. The sentences that refer to a nonexistence have an existence in the database and count in the accounting, and they must be somewhere, either in the splits among states that exist, or broomed together as a black hole.

There are many levels of existence in the model:

1. The level of numeric facts based on the relations innate to natural numbers,
2. Element (e,j) is occupying place (x,y) on plane resulting from reorder $A \leftrightarrow B$,
3. Cycles run concurrently that bring to realization reorder $A \leftrightarrow B$
4. That reorder $A \leftrightarrow B$ takes place is only one explanation for that element standing on that place: it could be that reorder $Q \leftrightarrow R$ takes place, in which case that element would have that place, too.
5. The system functions predictably (same as 2)
6. It is possible to deduct from observations of lower-level facts predictions regarding higher-level facts.

A logical treatise deals with the grammar of the logical language. We propose to extend the boundaries of the logical language to include being able to speak about such observations also, which relate and connect the individualities of logical tokens to their position among their peers, if and while the collection is subjected to periodic changes. It is grammatically correct to speak about ranks of individuals in a lineup, about places on planes of which the axes are two sorting orders, and to watch movement patterns of elements. We have proposed a system based on the antagonism between (a,b) . Due to this start off artefact, we look (project like into a Rorschach plate) into the numbers a system that is full of **duality**. The most important feature of the model are the **cycles**.

Our neurology causes us to experience *where* and *what* differently. In accounting reality, these describing dimensions are but different readings of properties of members of cycles. The underlying numbers offer both interval scale and ordinal scale readings, which we experience as distances and matter.

Let us consider a cycle consisting of members $\{a,b,c,d,e,f,g,h\}$. (Each of $a-h$ stands for a unique pair of (a,b) .)

There are 3 offsets for **reading in threes**

- 1.) $[a,b,c],[d,e,f],\dots$
- 2.) $[b,c,d],[e,f,g],\dots$
- 3.) $[c,d,e],[f,g,h],\dots$

There are 3 offsets for **reading in twos**

- 1.) $[a,b\rightarrow c],[b,c\rightarrow d],[c,d\rightarrow e],\dots$
- 2.) $[b,c\rightarrow d],[c,d\rightarrow e],[d,e\rightarrow f],\dots$
- 3.) $[c,d\rightarrow e],[d,e\rightarrow f],[e,f\rightarrow g],\dots$

Reading the cycle in *threes* one can conveniently execute turns from and into *three* planes that make up *one* Descartes-type space. We add up the *carry-a* values (similarly for the $\sum b$ values) and compare the 3 variants of one spatial-temporal unit to: a) the other two offsets, b) to the neutral value of 18 (*resp.* 33) for space as such. We put away 18 for space needs and what remains is that what is *dehors* of space, the rest, the anomaly of space, its content. (With courage, one could insinuate that this a concept for *mass*.) So far, the simplified

picture, where possible readings of a cycle are threaded together by their oscillations around the ideal value resulting from 3 successive members of a cycle, counted over all offsets.

The picture is, however, slightly more complicated than that. We must also account for the hereditary component in the description of the spatial properties of the members. There exists a past to the life of a logical element. Its *two* predecessors have bequeathed to it a *spatial momentum* which is the difference of the element to *18* (*resp.* *33*). The *value* of the element does not change; there will – as far as it is convenient – ‘always’ remain the logical property of the rest, remainder after having set aside *18* for the space. In normal circumstances, things can accelerate, within limits, without any change to their properties.

The spatial reading of a cycle compares the aggregate values of 3 successive members to *18* (*resp.* *33*) and applies corrections based on hereditary predictions of spatial properties. Counting the members in groups of *threes* establishes that only *one* predecessor exists for each element, the *third* element being a successor. Counting the members in groups of *twos*, one establishes *two* predecessors. The implications of *two* predecessors of a member of a cycle are numerically additive.

The spatial properties of an element are read out by counting in *twos*, the material properties of an element are read out by counting in *threes*.

3. Active Cooperation, Self-Experiment

Thank you for having ploughed through this tour d’horizon so far. Its aim was to present to you, what advances can be made in case one extends the number concept from its traditional context defined by the Sumerians and gives it an update more commensurate with techniques of our century. Your curiosity and interest have hopefully been alerted/activated. The ideal inner disposition of the ideal reader would be: “ok, so this much could be achieved by some devious tricks of counting cycles. But are there cycles at all? What do the words “order, cycle, steps, prediction” mean? Where is the beef of the invention?”

Here comes the moment which invites your active collaboration. Being passively receptive towards new thoughts is a half-step, like being seduced to discuss the beauties of Chess or Go, even as an outsider. Learning the rules and the first steps of the game is a different, second stage of learning. ***We ask you to learn the working principles of a hybrid of Sudokus with Rubik cubes.*** It appears *unfortunately necessary that you prepare for some work* with paper and pencil, and some of your books, in order to deeply comprehend the content this treatise is about.

Examples comparing this invention with previous inventions

The family of algorithms presented in the article is indeed new and for some, heretic. It needs efforts to understand what the paper talks about, right because the content is radically new.

In the time of the introduction of trigonometry, it was necessary for the audience to go to the window, look at two marks in the landscape and draw the angle they perceived onto a piece of paper. Without having actually have done so, it was incomprehensible what the invention is about.

In the time of the introduction of Arabic numerals, it was necessary for the audience to write up MMXXII and MDCCCIIIL and step-by-step translate the symbols into 2022 and 1848 respectively. Without having actually have done so, it was incomprehensible what the invention is about.

In the time of the introduction of binary numerals, it was necessary for the audience to write up 33 and 35 and step-by-step translate the symbols into 10001 and 10011 respectively. Without having actually have done so, it was incomprehensible what the invention is about.

In the time of the introduction of cycles (ordometric concepts generally), it is necessary for the audience to reorder say 10 to 12 books on a table, first into sequence author-subject, from which the sequence based on subject-author is manufactured. Without having actually have done so, it is incomprehensible what the invention is about.

Your attention is drawn to the fact, that **the property of being neither here nor there, being in transit, is a logical attribute** that exists everywhere where a collection exists in which the members are distinguishable. Spatial patterns come into existence as the logical consequence and implication of the basic units of our cognition having differing properties.

3.1. Self-experiment with physical objects

As babies can tell you, the only real way to understand a thing's properties is to taste, lick and chew it. Second comes the haptic impression, where one grabs the thing and shakes it. Inner convictions are built on fundamental experiences. The setup of the following ordering experiment encourages a deictic didactic by exercising the relevant logical procedures through ordering one's own things which one manipulates by one's own hands. (A hands-on logical treatise and the establishment of a fundamental insight.) In the Annex we publish a more elaborate, random exercise, which contains 2 cycles.

3.2. How to do it

One needs about a half dozen to a dozen books, place to manipulate them, paper, and pencil. Please pick any books from your shelf as you wish, but it appears they should be no less than 10 different ones. Please write author and subject keyword in a table. The Table 3 has 3 rows and as many columns as you are conducting the experiment with things.

Table 3. Schema for setup of self-experiment

Row 1, actual	$A_{\min}B_{\text{any}}$	$A_{2^{\text{nd min}}}B_{\text{any}}$	$A_{3^{\text{rd min}}}B_{\text{any}}$...
No of place	1	2	3	...
Row 3, target	$A_{\text{any}}B_{\min}$	$A_{\text{any}}B_{2^{\text{nd min}}}$	$A_{\text{any}}B_{3^{\text{rd min}}}$...

In row 1, the books are sorted on author first, subject keyword second. Using the alphabet as an etalon sequence, one will place the book with

$author_name=min$ on place 1. The property $subject_keyword = j$ comes into play only in that case, if one author has written several works with different subject keywords.

From this order we wish to proceed to the establishment of a new order. Beginning with book with $A_{min}B_{any}$ from the 1st place, we look up its value B_{any} . That value will determine its rank in the sequence $\{B_{min}, B_{2nd\ min}, B_{3rd\ min}, \dots\}$. That place is the correct place for this book. On that place, there is already a book which needs to be moved to its correct place.

Please order the books within the line they are presently in; the linear lineup forces one to have *two* books in one’s hands: the replacing one and that one which is being replaced. This experience is the deictic-haptic definition of a cycle. The cycle consists of acts of replacements and of movements from a place to a place. The last element of the cycle fills up that void which was vacated by the first element of the cycle, going to do the first push-away act.

Mathematicians will be able to explain the minimal number of diversities to be found on a minimal number of objects so that cycles will certainly appear. To an outsider, 12 seems to be on the safe side.

It is of course a random experiment if you line up 12 books on your table and rearrange them. Again, professionals will be able to tell, how many variants of cycles are there if reordering a random collection of (a,b) . Please share my bet that one will indeed find cycles.

3.3. Self-experiment by ordering logical objects

We have prepared a demonstration collection on which the principle can be explained without taking recourse to moving physical objects. We use 10 objects with two qualities each. The qualities we denote by $\{(1,2,\dots,10), (a,b,c,\dots,j)\}$.

Presently, the collection is in following order:

1c	2g	3a	4d	5b	6i	7e	8f	9j	10h
----	----	----	----	----	----	----	----	----	-----

The places themselves are enumerated

1	2	3	4	5	6	7	8	9	10
---	---	---	---	---	---	---	---	---	----

We wish to achieve following order:

3a	5b	1c	4d	7e	8f	2g	10h	6i	9j
----	----	----	----	----	----	----	-----	----	----

We give a step-by-step demonstration of the properties of cycles.

Nr of replacement	Element moving	From place	To place	Pushing away element	Arrives at empty place	Nr of cycle	No of member in cycle
1	1c	1	3	3a		1	1
2	3a	3	1		yes	1	2
3	2g	2	7	7e		2	1
4	7e	7	5	5b		2	2
5	5b	5	2		yes	2	3
6	4d	4	4		yes	3	1
7	6i	6	9	9j		4	1
8	9j	9	10	10h		4	2
9	10h	10	8	8f		4	3
10	8f	8	6		yes	4	4

3.5. Places connected: strings, filaments, cycles

Cycles are transient states. Books are in the process of being reordered, and their place is indeterminate, according to classical teachings. Their place is not completely indeterminate, because we see that there are geometric connections among groups of elements during periodic reorders. From among the indeterminate places, the possible ones are restricted to positions on a string/cycle, with defined predecessors and successors. The placement on a plane can be read out from our exchange objects, here: books; we create a grid with as many units as we have experimental objects. One axis of the grid are the sequential positions in the author-sorting, the other axis are the sequential positions on title-sorting. These x,y values give a perfect place on this plane to each of the elements. We draw a line that connects the coordinates of such books that have replaced each other, one after the other. The line connecting is the geometrical representation of a cycle.

Thank you for giving a thought to these encouragements. In the following, we shall turn to the technical side of the proposition. We suggest the creation of an etalon collection, the members of which are subjected to periodic reorders. The movement patterns of the logical units are prescribed by the same outside force which gave natural numbers their properties. We deal here with Laws of Nature, expressed in the lyrics of accountants.

4. The Etalon Collection

The tool we use to investigate the interdependence $\{value, position, order\}$ is a collection of simple logical tokens, which collection contains all variants for a whole to consist of two parts, if the two parts can have no more than d categories of properties.

For $d = 16$, $n = 136$. We demonstrate the principle on a collection – cohort – with 16 different variants for (a,b) . The cohort includes all variants of possibilities for a whole to be split into two parts, and concurrently all variants for two parts to fuse into one whole. Such, the collection can be used as an etalon collection.

4.1. The Table of Cohorts

The logical symbols we exercise with (the probands of the experiment) are pairs of natural numbers (a,b) , where $a \leq b$. They come in cohorts. For deictic reason, we show the first 4 cohorts (see Table 4).

Table 4. Elements of the cohort

No of distinct properties d	No of distinct elements in the cohort n_d	Elements of the cohort
1	1	$(1,1)$
2	3	$(1,1),(1,2),(2,2)$
3	6	$(1,1),(1,2),(1,3),(2,2),(2,3),(3,3)$
4	10	$(1,1),(1,2),(1,3),(1,4),(2,2),(2,3),(2,4),(3,3),(3,4),(4,4)$

Connection to OEIS: The number of members is driven by d , the number of diverse variants of (a,b) : this agrees to the triangular numbers oeis.org/A000217. [8]

Names and mnemonics: The name *logical primitives* for the collection comes from a suggestion by Marcus Abundis. [2] They represent semantically anything that is being made up of *two* parts. Our probands in the experiment can also be visualized as a pair, like a married couple or like centaurs. The restriction $a \leq b$ refers to a concept, where girls are not bigger than boys in a couple, and the human part of a centaur is not bigger than the horse part of it. The foreground, that is the case, cannot exceed its background, that is not the case.

Size of the cohort chosen: Considering the relations shown in oeis.org/A242615 [4] we have decided to discuss here the observations registered by watching a cohort of diversity category $d = 16$, yielding $n = 136$ different logical primitives. A

cohort of this size can utilize the changes of the proportion *diverse/similar*, which is $f(n)$, to the maximal extent, with the highest efficiency.

4.2. Ordering and Sorting

We conduct ordering and sorting operations on the cohort. There is a blind spot in the perception of the results of ordering and sorting in theoretical mathematics. This because the tradition introduced by the Sumerians de-individualizes the logical elements $\{1,2,3,\dots\}$; each of these elements is understood to be a collection of lowest-level units of 1, as many of 1, as the place is far away from Zero on \mathbf{N} on which the element stands.

Elements that are indistinguishable can be in any linear order: we are not able to perceive any difference between the arguments $\{aaaaaa\} = \{aaaaaa\}$. Therefore, patterns that are observable during reorders – cycles – are not perceptible (cannot be admitted into cognition), as long as it is by education and tradition *unthinkable* that units are diverse among each other. Here, we split the $\{value, position\}$ pair of properties of natural numbers. (Remark: Would be a good title in sociology, group psychology, economics: *Value and Position*.)

4.3. A242615 basis for size

We understand the *position* part of the description of the logical elements to be using an interval scale, \mathbf{N} . The *value* part of the description of the logical elements uses an *ordinal scale*, on which the intervals are **not equally spaced**. Only the symbols $\{<,=,>\}$ are used to determine neighborhood relations. $(val(n_i) - val(n_{i-1}) \{<,=,>\} pos(n_i) - pos(n_{i-1}))$ The distance $val(i), val(j)$ **does not necessarily agree** to the distance $pos(i), pos(j)$. There exists an inbuilt discongruence (which we shall call one of the forms of information). The hypothesis lurks on the horizon, that the Grand Total of distances between elements of a well-ordered collection remains within range limits $f(n)$.

In www.oeis.org/A242615 [4] the relation between the maximal number of distinct sentences that can be said on the two scales is contrasted. As the numbers show, there exists an accounting inexactitude, which renders the whole system

of references to contain inner contradictions of a numeric type. The relative inexactitude reaches one whole unit of \mathbf{N} as $n > \sim (136, 137)$. The accounting translation between *{number of objects, number of position-related statements possible and number of value-related statements possible}*, is done optimally with diversity categories that number 16, of which limit the size of the experimental cohort of 136 follows.

4.4. Pairs

Our logical elements are each an individual. There is only one element with the value properties (a,b) in the cohort. The elements are a pair of natural numbers $a,b; a,b \leq 16; a \leq b$.

(Remark: This exercise is also redoing Mendel's experiments with green and yellow garden peas. Our elements are each a plant with maternal and paternal properties (a,b) .)

4.5. Cohorts included

We use Cohort 16. Of course, this cohort includes all cohorts 15,14,13,... too. A finer differentiation of subcollections is included in the possibilities of consisting of two parts. Further splittings and fusings will undoubtedly take place. We discuss here the general outline of a model that allows consolidating rectangular concepts with biologic organizational forms. The actual technical procedures will be written by professionals: here we draw a simplified schematic picture.

4.6. Aspects

Coming back to $A242615$, one sees that the maximum of the deviation between position-related sentences and value-related sentences is $n \sim 66$. The number of distinct ordinal diversity classes is at that value of $n: d_{ord} \sim 15; (\ln(A000041(66)))$. One needs no more than 15 distinct queries (dimensions) to

describe a collection regarding the similarities within groups and diversities among groups that exist among elements.

We have used 9 describing aspects to sort and order the collection on. These are: $a, b, a+b, b-2a, b-a, 2b-3a, a-2b, (d+1)-(a+b), 2a-3b$, in this sequence. In our case $d=16$.

The describing aspects diminish in discriminatory efficiency in a sequence of queries (test campaigns). A successor test cannot avoid turning up such elements in the results of its query which have already been enumerated (found, tagged) during a predecessor test, under a different eligibility criterium.

About a collection with a limited number of members, only a limited number of distinct sentences can be said. The later sweeps will turn up fewer such objects that had not been tagged before. After a finite number of sentences, all that can be said about the finite collection will have been said, and one starts repeating oneself (opening a way to learning). The number of different aspects under which to describe the world is also limited, if the world contains a limited number of constituents.

There is a natural limit to categorizing, assembling into groups, of elements of a finite collection. This is reached as soon as each member has become an individual, by being member of such a combination of groups which exists only once. In the model, such individuals revert to being counted in *interval scales*, too. The concept of distances between individuals becomes relevant (calculable), as opposed to distances between members of swarms, which can be only established in an aggregate form (see e.g. *murmuration*).

We certainly surpass the required ~ 15 aspects, as we use two aspects to sort and order the collection on. We have $9 * 8$ pairs of aspects, each of the aspects shown above being once the first, outer sorting criterium and once the second, inner ordering criterium. We shall refer in the sequel to the aspect as being one of 72 ordering pairs of criteria.

4.7. Ordering

We create sequential, linear orders among the elements by sorting them on each of the 72 sorting criteria. We create a table SQ, wherein we register the $\{(a,b), \text{ sorting order, sequential number}\}$ properties of the elements.

4.8. Two orderings, one place

Considering the orders AB, BA we see that element $(1,3)$ is on different places. (Order AB: $(1,1),(1,2),(1,3),\dots$; Order BA: $(1,1),(1,2),(2,2),(1,3),\dots$)

We draw a plane with the axes AB, BA . Element $(1,3)$ will have the coordinates: $x=3, y=4$. On this spot, the element is causing no controversy about whether it is ordered according to AB or to BA (see Fig. 1). **The place on a plane is a logical compromise.**

4.9. Reorderings

We generate a table T in which we register the travel of each element in each of 72 sorting orders to the place one of 71 different sorting orders assigns to it. This data set contains the columns: $\{(a,b), \text{ sorting_order_from, place_from, sorting_order_to, place_to}\}$.

4.10. Cycles

We extract from table T a new table of Cycles, Table C. Here we register $\{\text{sorting_order_from, sorting_order_to, cycle nr, step nr, (a,b)}\}$

We generate cycles by observing the series of *push-away incidents* which happen as an element moves to a place which is occupied by a different element, until the last element having been pushed away from its present place finds that place, which the “first” element has vacated in our accounting procedure.

The appurtenance of an element to a cycle is a numeric fact and is an implication of the two natural numbers' value properties which make up the logical element, and an implication of the fact that two different sorting orders are different. **The cycles are a logical fact.**

5. Patterns Observed

5.1. Deictic definition of the term 'cycles'

We shall now discuss types and properties of cycles. It is not the task of a psychologist to give names to properties of collections of numbers. In order to avoid any trespassing on the domain of Mathematics, the term 'cycle' refers to that logical-numeric relation which is defined by www.oeis.org/A235647.

5.2. Stays in place or direct exchange

Elements that keep their place or directly exchange places with one different element are considered to be special cases. We discuss here cycles that contain at least 3 elements.

5.3. The concept of 'now'

The members of a cycle are ordered sequentially. The observer can invent an instance of “**now**”, where *now* refers to such elements of members of concurrently running cycles that are concurrently the case (as opposed to such members of the cycles that were before or will follow the element which is *now*).

5.4. Standard cycles

We find 10 reorders termed *standard (space-generating) reorders*. These have the properties that each consists of 45 cycles with 3 members where $\sum a = 18$, $\sum b = 33$, and 1 member with the numeric property (6,11).



5.5. Planes and spaces

Of the planes that are a geometric representation of the 10 standard reorders' axes' data, we assemble 2 rectangular, Descartes-type spaces, which we call *Euclid spaces*. The name refers to the fact that the central element is a deictic definition of the concept of a point, without needing an axiomatic introduction of the idea. The two remaining planes transcend both Euclid spaces.

Dropping the *second, inner* sorting criterium of the standard reorders' axes, we assemble a 3rd rectangular, Descartes-type space, which we call *Newton space*. The name refers to the fact, that of the 3 axes of the Newton space, *one* is directed, and additive rules of **N** apply on it, being such well suited to model **gravity**, as a fundamental, archaic, pre-axiomatic relation among logical symbols. The axes of the Newton space are: $x: b-2a$, $y: a-2b$, $z: a+b$. The coordinate system in the Newton, 3D space is in itself *ambiguous*, because each measure on e.g. $a+b$ can be resolved in *two interpretations*: once referring to a position on $a+b, a$, once referring to $a+b, b$ in the underlying Euclid spaces. An exact reference on the properties of spaces surrounding *one* point in the 3D space requires *three* sequenced statements (which refer to the 3 axes of the Newton space), where on each of the *three* places, *one of a pair* designates, which Euclid subspace connects with which Euclid subspace in the course of the turns in the Newton space. (There are *two pairs*, because the other pair would not work anyway. E.g. $a+b, a$ connects only to $b-2a, a$, not to $b-2a, a-2b$.)

5.6. Axes, planes, turns

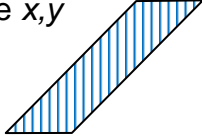
The logical continuity is maintained by three repetitions of the rule: two linear ranks equal one planar place. There are rules, based on immanent properties of natural numbers, which determine the mechanics of where, what and when. (see Figure 6)

$x: b-2a$, transversal (lateral)	$z: a+b$, vertical (gravity)	$y: a-2b$, horizontal (sagittal)
Plane x,y 	Plane x,z 	Plane y,z 
Turn 1: Plane $x,y \rightarrow$ axis $x \rightarrow$ plane x,z	Turn 2: Plane $x,z \rightarrow$ axis $z \rightarrow$ Plane z,y	Turn 3: Plane $z,y \rightarrow$ axis $y \rightarrow$ plane x,y

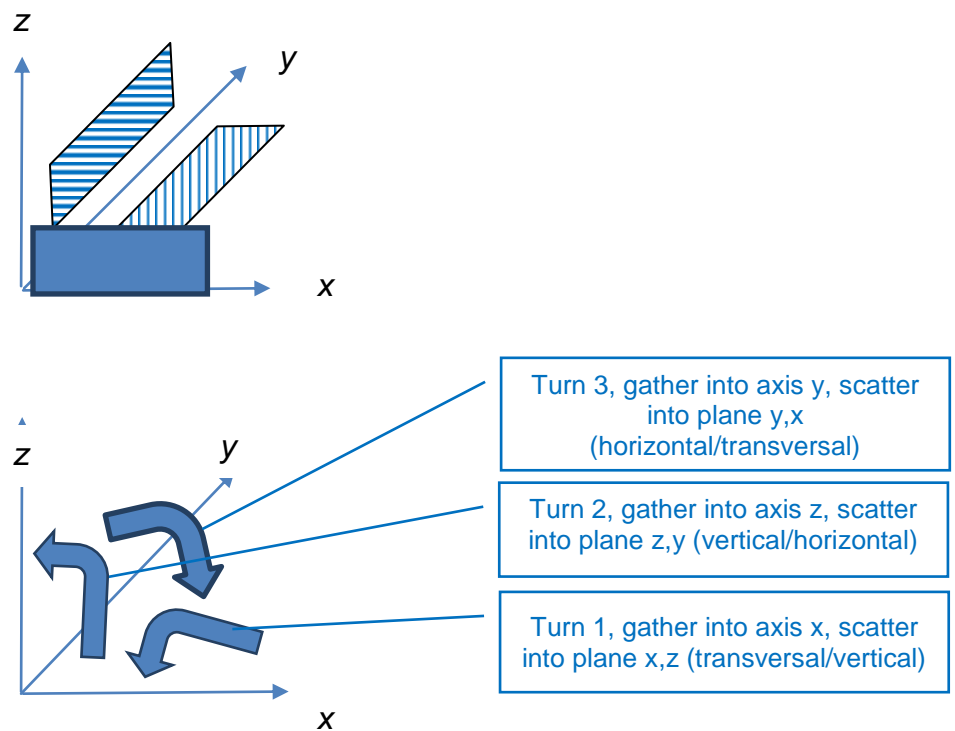

Fig. 6. Overview of movements in 3 phases

6. Interpretation

6.1. Wittgenstein’s concept of true logical sentences

It is possible to describe the task reader was asked to experiment with. One can communicate exactly and understandably about the task of ordering and reordering say 10 books on the sorting criteria title, author, and also on the

sorting criteria author, title. One can also express in logical sentences the patterns of push-away and replacement acts during the procedure of reorder. The whole exercise is permissible, and its conduct and results can be formulated in grammatically correct logical sentences.

6.2. $a = a$ dissected, left and right defined

Let me add as an aside, that the Holy Grail of sentence logic, namely $a = a$ can now be explained in more detail. In its traditional understanding, we silently state, that we do not make any difference between *left*, *right*. We can now point to the **two central elements** which are well suited to depict $a = a$ in geometry, opening ways to a deeper discussion. It is true, that their underlying numeric values are identical and the logical statements of both refer to the spatial position of member (6,11) among its peers in a cohort. Yet, there are *two* central elements which we can distinguish. Their value agrees, but their positions are different. The central elements connect the pre-mathematical axiomatic difference between *left* – *right* to numerical results generated by ordering natural numbers. We can now define by deictic methods what we mean by saying *left*, *right*, without fixating the perspective of a spectator. RNA and DNA are left – right relative to each other.

6.3. Logical continuity and Heisenberg’s cat

We see the DNA as an instruction to find an element of \mathbf{N} which is the number of one of a collection of possible organisms. We call the organism’s number i_{org} a member of a variant \mathbf{N}_{org} . To this element points one i_{seq} , which is a member of a variant \mathbf{N}_{seq} . The task is to find the method of matching on the ordinary \mathbf{N} . First, we need to establish logical continuity. We state

$$Pos(i, \text{peers}, \text{linear}, \text{property}) \leftrightarrow Seq_{nr}(\text{order})$$

$$Pos(i, \text{peers}, 2 \text{ orders}, 2 \text{ properties}) \leftrightarrow Planar_place(2 \text{ axes})$$

That is, the planar place of an element is equivalent to two linear ranks on two specific properties. If we have 3 such planes that are stitched together to create *one* 3D space, we can maintain logical continuity (the required tautology) by saying:

...elements scatter into plane from sequences, elements gather into sequence from planes, elements scatter into plane from sequences, ...

The tautology between two linear values of a sequence and one pair of coordinates on a plane is maintained.

The indecisiveness between existence and non-existence comes from the contrast in our perception *foreground – background*. If we base our perception on a series of moments of *now*, we discuss those cases, where the push-aways were successful and the elements of the cycle are at those planar coordinates to which they belong. In each moment of *now*, the elements and the planar grids exist. In the split between instances of *now* the actual rearrangement takes place. The cycles are like athletes (cats?) who run by making jumps. If we count all athletes who will eventually contact Earth, we shall arrive at a differing number to that if we count athletes who *are now* in contact with Earth. Elements in transit have differing properties to elements stationary. Quantum entanglement appears to be constructing ideas in this direction. In a dichotomy: the world can be described by two languages: one, in which the elements do have geometric coordinates, and one in which the geometric relations do not exist. The concept of distance in the interval scale system of concepts deteriorates into the concept of distance in the ordinal scale system of concepts. Different rules apply to objects that are on their place *as expected* against objects that are in transit, about which we have much less *expectations*.

7. Information

The present work has much to thank to the working group “Foundation of Information Science”, established by Prof. Pedro C Marijuán of Zaragoza Polytechnics in 1997. The red line in all our discussions was the meaning of the term ‘information’. We have learnt many aspects, layers, and connotations of the idea of information during our long common work.

7.1. Semantic: the extent of being otherwise

The proposal is to use the mnemonic that information is the deviation between expected and observed, which is the extent of being otherwise. We have had to confront the traditional delineation by mathematics, namely that mathematics is

that collection of ideas where everything is as expected and by definition nothing is ever otherwise. We had to find an inner crack in the system which allows for two results of correct readings of the world which are at discrepancy with each other.

Thankfully, there exists a slight inner incongruence in the numbering system. It is based on the differing architecture of world views, based on similarity and diversity. The present treatise does not go into the subject of how foreground – background contrasts influence the perception – and therefore, of counting – similarities and diversities. Here, we have shown that using *identically spaced* axes for units of counting – like the standard cycles’ Descartes distances – alongside logical statements that derive from measurements of *ordinal scales*, will create manifold patterns and forms.

On the most basic and general level, information can be shown on a graph of A242615 as the two areas, wherein there is a relative deficit resp. surplus (see *Figure 7*).

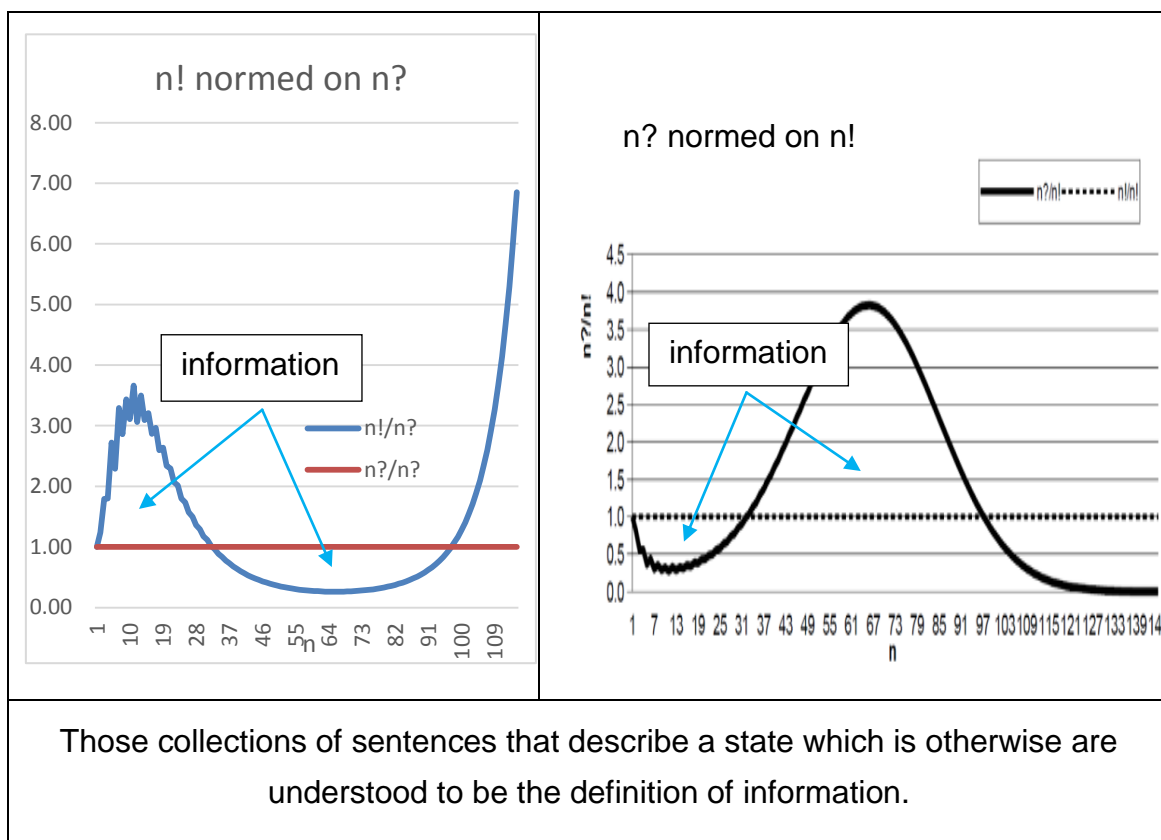

Figure 7. A242615, in two forms

7.2. Two versions: $b = c - a$; $a = c - b$

Information has by its nature two forms: once the expected whole relative to the observed part a and once the expected whole relative to the observed part b . When seeing a part of the whole, we estimate both the whole and the missing part. If we conclude the probable whole from an observed part, the exactitude of our guesses will increase with the proportion of the part we actually see. Yet, **there is an inexactitude which we call information**. It has two forms:

$$\text{Information: } b_{est} = c_{estA} - a_{obs}; a_{est} = c_{estB} - b_{obs}$$

$$C_{estA} \{<, =, >\} C_{estB}$$

7.3. Information: Δ (observed, expected)

This is the ultimate rhetorical challenge: argue that a logical system possesses inherent contradictions, and that elements within a logical system have contradictory properties. Yet, this is what needs to be done here.

We need something to be concurrently $\langle such_1 \rangle$, $\langle such_2 \rangle$, with $\langle such_1 \rangle \{<, =, >\} \langle such_2 \rangle$. Then we can call $\langle such_i \rangle a$, and $\langle such_j \rangle b$. (Example: embryo learns to distinguish heart rhythm of mother against sleep rhythm of mother.) We need to have two different parts of the world that relate to each other. The stricter and more close the relations between a, b , the less inexactitude will be created during foretelling the properties of c , based on what we observe to be a , resp. b .

The relation between observed and expected stands true also in a temporal understanding of cycles. (Example: We know that the Sun is about to set, we have consumed part a of the daily cycle of c . Now we expect that evening, night and the next day shall follow as expected.) On observing some occurrences to be the case, we expect a continuation under the assumptions of orders prevailing. The orders prevailing had already brought about the state, that such occurrences are there as is the observable case. Then, it is reasonable to expect that orders prevailing do exist and generate orders. Importantly, there are alternatives that can come into existence, notwithstanding our expectations.

The existence of alternatives must be reflected in the general landscape of axioms about the numbering system, too. If j can mean k in dependence of context, the basic properties of units need to be sufficiently flexible and context dependent. There is a web of interdependences among logical symbols. This web is the possibilities of orders to actualize (realize) some of the contexts. The context determines with which other elements any given element will team up during reorders. The context is one of the components of the order, but priorities among orders change periodically, too. There is a connotation of market around the value of an element, inasmuch the periodic changes render its presence less relevant.

Defining information as the extent of being otherwise presupposes that there are mutual expectations against the other participant. There are as many variants of information, as there are many instances of two things that can be such or otherwise relative to each other. This definition is not practical, being too near to the concept of subtraction.

7.4. Arbitrary etalon

Once there is an agreement that information is the extent of the deviation, one has only to find two things that are deviating to each other in a discernible way and agree that these two things are what to read off definitions from. These two deviate among each other to the extent of *Unit*.

One could pick two elementary cycles from the reorder $ab \leftrightarrow ba$ and use these as etalon patterns to read definitions off from. (Example: building cathedrals, the masons used a *Measurement Stone* to recalibrate their individual measuring rods on.)

We offer a humble proposal by publishing two cycles of the simplest reorder $ab \leftrightarrow ba$ and suggesting some examples of naming numeric values, thereby giving meaning to them. We use two etalons to stress that information has one general form of being the deviation between two extents of *observed vs. expected*, measured twice ($a \rightarrow b, b \rightarrow a$) but a great number of particularities, because the two that are compared to each other can be freely chosen.

Within the context of the present essay, only such propositions can be offered regarding a definition of the term "information", which resemble the proposition to call that length "1 meter" which agrees to the length of a piece of metal kept in a safe place in Paris.

Such a definition has the advantage of being clearly demonstrable, with the drawback of touching only on the most obvious way to establish the concept. We can propose to use the reorder $[ab] \leftrightarrow [ba]$, and within that, cycles No 3, No 6.

We shall extract from the general form of the reorder $[ab] \leftrightarrow [ba]$ two cycles which we propose to use as arbitrary etalon for the term 'information' (see Figure 8)

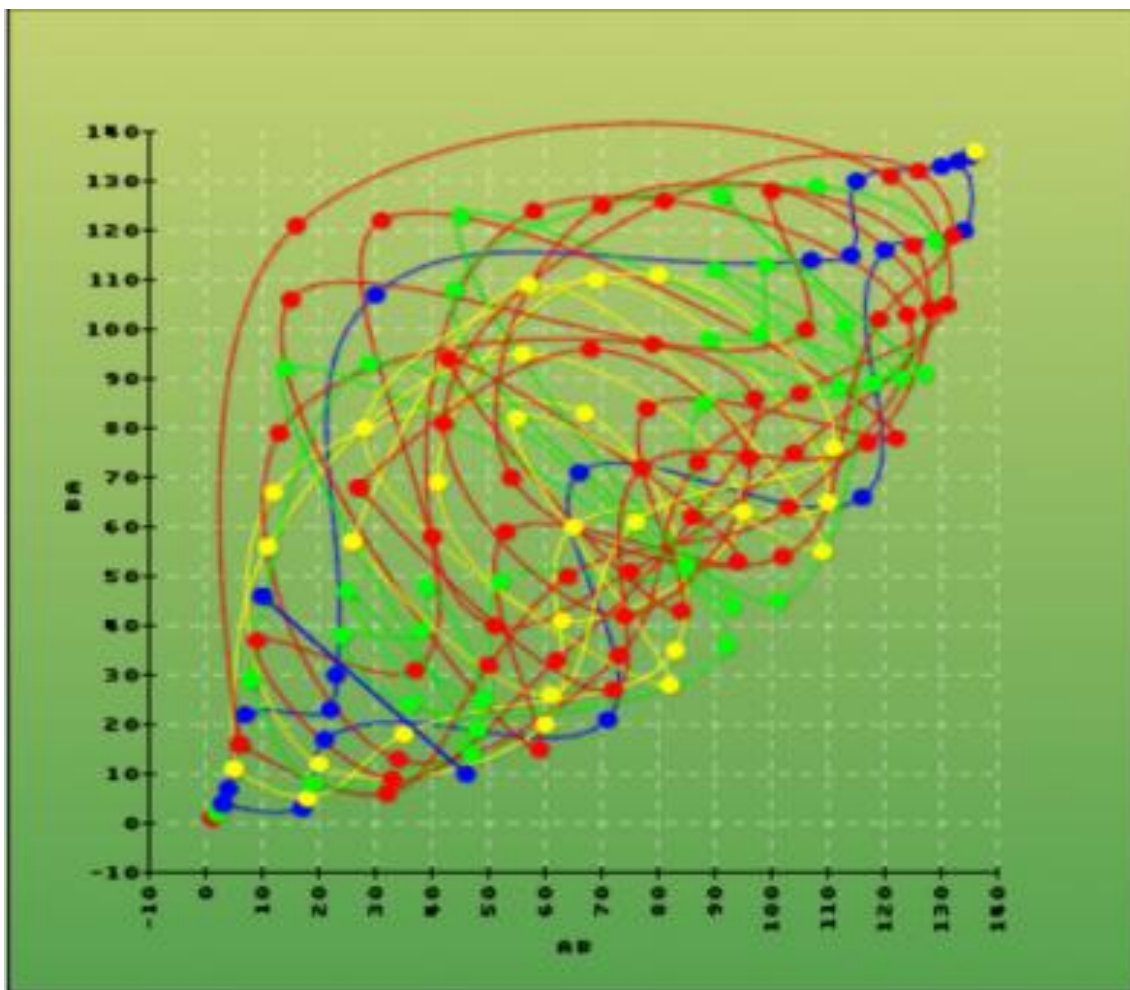
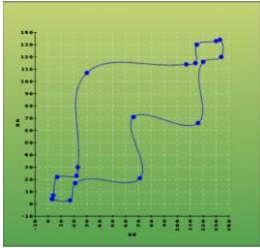
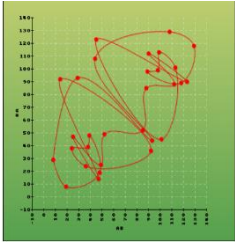

Figure 8: Cycles of reorder $[ab] \leftrightarrow [ba]$

This is the general form of the reorder **[ab]** ↔ **[ba]** with the maximally efficient number of diversities of $d=16$, causing Cohort **C16** to contain $n=d(d+1)/2=136$ elements. Of these, we have chosen cycles No 3, No 6, to be used as etalon unit of inner deviations Δ (**observed, expected**), which is the definition of information.

The cycles have many different properties. The proportion between the aggregates for a,b and geometric properties of a cycle is descriptive of a cycle. (see Table 5)

Table 5: Deictic definition of the term “information”

<i>Name:</i>	Cycle 3, ($d=16$, $(a,b),[ab],[ba]$)			Cycle 6, $(d=16,(a,b),$ $[ab],[ba])$
<i>Picture:</i>				
<i>Basic Properties:</i>	<i>members: 18</i>			<i>members: 30</i>
	$Carry_a = \sum a$			$Carry_a = \sum a$
	$Carry_b = \sum b$			$Carry_b = \sum b$

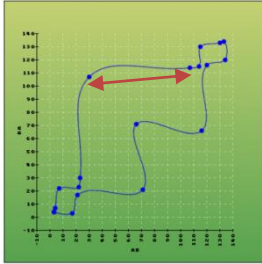
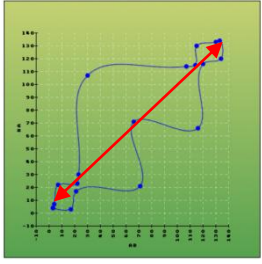
	$Run: \sum dist i$		$Run: \sum dist i$
	$Extent: max(dist(j,k))$		$Extent: max(dist(j,k))$
<i>Derived Properties:</i>	<i>run per members</i>		<i>run per members</i>
	<i>members per extent</i>		<i>members per extent</i>
	<i>carry per run</i>		<i>carry per run</i>
Information:	$(Carry_b - Carry_a)/run$		$(Carry_b - Carry_a)/run$

The concept is that of an example of elementary, inbuilt inner deviation among parts of a whole. The parts not being uniform, the differences among them will also have several forms and types. One of the forms in one of types of inner deviations within the system is pointed out as an example. How near is the value collection $\{carry_a, carry_b, run\}$ to each their most usual values? The degree of *deviation to the most usual value* gives the example a semantic meaning towards how much $\{unbalanced, stretched, loaded, unusual, predictable, etc.\}$ a cycle can be, relative to its peers. The unit of *information* has been given an, arbitrary, definition here. The unit of *discongruence* is to be

extracted by professionals. It would be a happy coincidence if its forms agreed to some quantum constants.

One may well understand information to be the result of comparison of respective values between the two cycles. Information can also refer to the deviation in some properties between two reorders. (Example: the difference between the force of tides and the force of day/night periodicity affects fish differently than birds.)

Information should merge into the concept of predictability as one of its constituents.

8. Resume

The facts have been presented. Like in the case of the moons of Jupiter, the facts are there to see for anyone who knows how to use simple tools (there: telescope, here: computers). Galilei's observations of the moons have led to the collapse of the prevailing, enforced, traditional view of the world, in which Earth sits in the middle of the world and heavenly bodies circle around it. What traditional, outdated views of the world will collapse now, that we have found and presented factual evidence that out of natural numbers, a model arises which is incomparably more versatile than the logical space the Sumerians have created? We manipulate the same symbols the Sumerians have evolved, by applying brute force computing. The previously existing relations among symbols remain existing. By observing the patterns resulting from reorderings, we have added *to the dictionary*, not to the collection of facts. The underlying numeric relations have always been there, what we did is archeology on fundamentals that were not visible to the naked eye. Where do these traces of excavated fundamentals lead us to? What new edifices of thoughts can be erected? Which open controversies can now be considered solved?

We shall list a few perspectives as appetizers. Technical research will put the following ideas in adequate words.

8.1. End to monocausal explanations

One general idea: *that the elements are in a perpetual process of periodic changes* comes closest to a monocausal explanation; the change itself would be the ultimate Cause [14]. On Cohort Nr 16, the etalon collection, on our folk of logical primitives, using *these specific* sorting and ordering aspects, we arrive at results that indeed possess a monocausal explanation: we have set up the rules in such a fashion that these results of the experiments will appear. The setup itself is the artefact that renders results of the experiment trivial in the sense of tautologic, which is a good thing in accounting.

Even under tautologic circumstances, having by the setup determined the range of variants of outcomes, there is an argument against monocausality: *reorders come in cycles that run parallel*. Each of the cycles contributes to the reorder, but none of the cycles is sufficient for the reorder, none of them can serve alone as a monocausal explanation. Things belong together due to some deep properties they possess: these properties are manifold. The incompleteness, partial nonfulfillment of the change is a part of the inner setup of interacting logical symbols.

There is a third reason which invalidates the idea of monocausal explanations: not only are we confronted with a concept of an axiomatic continual reorganization of the contents of our model of the world, but there is an additional quirk with regard to the *number of participants* of the assembly. Nature has found in her grace convenient to arrange the existence of two additional variants of **N** to stand alongside Good Old Faithful **N**, namely **Nseq**, **Ncomm**, where **Nseq** is the name of the sequence onto which the reverse of that combinatorial function points, which counts sequential distinctions among the elements of the assembly, thus giving a description of the *similarity* properties of the state of the assembly. **Ncomm** is the name of the sequence onto which the reverse of that combinatorial function points, which counts commutative distinctions among the elements of the assembly, thus giving a description of the *diversity* properties of the state of the assembly. This interdependence is pictured in A242615. We compare the two results to the two questions: “*How many objects are needed to generate x {permutations, structures}?*” There exists a sliding proportion between the two translation

functions $x \leftrightarrow f^{-1}(f_{seq, comm}(n))$. At the *Eddington threshold*, 136 objects generate roughly as many logical relations (of the sequenced kind) as 137 objects generate logical relations (of the structural kind). Lower than that threshold, there is a *Bazaar* of exchange terms between zillions of logical relations and one physical object. There is a three-way interdependence between *{number of objects, number of sequential relations, number of commutative relations}* and the translation coefficients are heavily indexed by the properties of the third argument.

In a cultural perspective, implications of the facts presented appear to favor a *polytheistic, animalistic* embedding of the rational world into a system of beliefs. There appear to exist principles, rules, contexts of many variants that regulate the interactions of the members of the etalon collection. There exists no single overriding principle. The number of variants of ideal orders is above One. The number of ideal strategies to achieve one of the ideal orders is above One.

8.2. Concept of context and meaning

Periodic changes impose by their nature contexts. It is within the context of a cycle that an element is the case on specific planar places, and therefore in spatial positions, as far as a space is stitched together by planes. The cycles are in a context of reorder, the reorders are in the context of periodic changes. The periodic changes are in a context with each other. These **contexts** are facts of Nature, inasmuch as natural numbers are a creation of Nature, and **are a-priori in existence**.

The meaning appears at first to be nothing but a construct of the human brain. Information is the extent of deviation between expected and observed within *one* context. For the formal definition, it is of secondary relevance, *which two* numeric concepts are compared with each other. In this work, we have discussed the translation mechanism applied to two forms of information storage: sequenced and commutative meaning of symbols on elements. We used the concept of ideal circumstances to demonstrate the idea on the examples of genetics and memory. The ideal circumstances can take place in an assembly that is *euregulated*. Around the ideal state there exists a swarm of states that are almost ideal, not one of the ideal states although within the

tolerance limits. From everyday life, we have a clear concept of what a normal state of the affairs is and can contrast the idea against a concept of a hoped for, imagined better state of the affairs. We assume a *human capacity* to be in existence, given to us by Nature, which allows us to extrapolate over *many* contexts, **combining the respective euregulated values, thereby creating a concept of Utopia.** The utopic concept is an assembly of all possible ideal states. As was said above, the concept of ‘optimally ordered state’ exists only in *manifold variants*. There exists no *unique, single optimal state*, nor exist single, *unique optimal strategies* to reach the *maximally euregulated state*.

We define *meaning* to be the measure of closeness of a given state to the euregulated (utopic, ideal) state it is compared with. Meaning is one of the forms of information. In this, meaningful form we relate a (description of) state of the world not to any other (description of) state of the world but use a defined reference state of the world. **Information is comparable to the distance between two points. Meaning is comparable to the distance of two points to the central elements.** Relating the observed state to one of the euregulated states uses a broader spectrum of contexts.

Assembling the world view can only happen by selecting such aspects of description which one prefers to be the foreground and leaving the others to serve as the background. There obviously exist **reference structures of relations of most usual values among each other** also in Nature, as a-priori facts. Otherwise, animals would not be able to recognize *schemata*. The existence of a-priori facts gives rise to the existence of a-priori relations among these facts. Among these relations, there will be some which are integral to the highest number of them to the maximal extent. These would be the schemata, perceptual archetypes in the sense of C G Jung [9]. Perceptual archetypes are similar to materially existing logical archetypes, by being variants of agglomerations of most usual values.

The meaning is a degree of fit of a context in the melee resp. order of other contexts. In human life, ascribing of meaning is highly subjective and situation dependent. (Example: information describes the properties of a pass of the ball between two players of soccer. Meaning – in the formal philosophical sense – orients the pass relative to the two goalposts, using the central elements for

such. Meaning differences among humans come from their diverting ideas, what and where the goal posts are.)

8.3. Cleaning up the dictionary

Observing how periodic changes affect a collection of logical primitives, one finds typical patterns. The patterns come to us as entries in a table. It needs efforts to translate the numbers in tables into concepts of space, matter in transit in space, types of matter, 3 ticks in a step, types of planes, certainty of prediction of the next step based on two previous steps, and so forth. The numbers in the tables are, like the facts of moons circling Jupiter, similarly a-priori facts. The observation of the moons has served as steppingstone towards a science of planetary mechanics. The numbers in the tables will serve as steppingstones towards a science of interdependence between *{number, similarity, diversity, periodic changes, order, place, position, stability, predictability, sustainability}*. The common coin among these will be *certainty about deviations from the most usual ranges of values*.

The common exchange rate, currency for interactions among cycles, members of cycles and periodic changes can also be interpreted as *predictability* with synonyms of *unit of inner consistency, unit of move towards/away maximal fit*. It is in a formal sense irrelevant whether the prediction refers to a coming disaster or to a normal continuation of business. The main question is how we determine the properties of the *Unit etalon of utopic state* (maximally well-regulated, super-optimal, ideal state), as there exist no single, unique variants of the concept. The next level of abstraction brings us close to religion, as we discuss, which priorities among properties of properties are the most basic.

The numbers contained in the objective meaning and content of the present treatise offer a clean slate for a world view that uses periodicities, types, predictabilities, order as its fundamental concepts. The numbers are a Rosetta stone of interpretations: what for one is energy, is in the other descriptive language potential and in the third language (web of concepts) information or meaning. Redrawing a map of relations among concepts can be attempted, using the reference grid provided by the numbers in the tables.

The cycles are a picture of what takes place in Nature, at least of that segment of her proceedings about which we can speak understandably. The task before us is the opposite of what we do with a Rorschach plate. Now, we have to *read out* pictures from the manifold pixels. The spatial web the readings of triads, in the sense of the standard reorders, create, accommodate a basic duality. The two subspaces interact and create by their interaction (interference) patterns one, common 3D space with its over- and under densities. Two further planes transcend each of the spaces. Distinct types of unavoidable agglomerations appear. There exists the concept of ticks of one main and of several local clocks. The system continuously turns in three phases. Altogether, the numeric model shows a credible general picture of Nature. One has a plethora of measurements to make to establish a clear dictionary (*musica universalis*).

8.4. Decision on the a-priori controversy

We have seen that relations exist **a-priori** among natural numbers. The implication of facts is the relations among facts. The relations also have a-priori properties. If there are forces and principles in Nature that exist a-priori, then animalistic religions have a point.

Reflexes, patterns of perception, archetypes are among the proofs that our nervous system has adapted to an environment in which **external a-priori principles do indeed exist**. Among Nature's principles there are some which interact with and regulate each other. The movements of the elements of our etalon collection show that such interacting loops are indeed possible. This means that the Creation has been found to be replicable in a mental experiment by using logical tokens. We have the accounting tools to generate spectacles. This again is in breach of an unspoken taboo: no construction based on **N** and its derivatives can ever explode, conceptually. There exists, by definition, no deviation within the traditional system using only **one variant of N** that could add up to an intolerable extent. Nature has provided us with **two additional variants of N**, and we are in the process of learning how to make use of their respective deviations as accounting entries. The deviation itself is context independent. There are many levels, ranges, thresholds, limits, equivalence points and critical densities in the numeric patterns the wanderings of the logical primitives present.

In monotheistic cultures, it is a breach of taboos to speak of Nature as if she was a multitude of deities, each following their wishes. Yet, the picture of the etalon collection being in its usual, predictable, well-regulated state (collection of states) is very reminiscent of a Hindu or ancient Greek heaven. There are about a dozen aspects, main ordering principles. The general order will be a quasi-stable one, with oscillations and local phenomena. The requirements imposed by the concurrently existing but different ordering principles can lead to controversies and contradictions. Like in the equation *two linear ranks = one planar place*, controversies and contradictions can be navigated by translating the most annoying content of the controversy into a unit of compromise on a different plane. There will come into existence typical exchange patterns: maybe these could also count as perceptual archetypes, which a-priori exist.

We state that the euredulated variants of states have a descriptive value range, say $0 < \theta < 1$, below which there are too few logical relations per object, above which there are too few objects for that many relations. Under- and overregulated systems are the boundaries of a well-regulated system. The ideally regulated system as such, the Utopian system, can exist as a theoretical construct; in logical reality we will encounter only a few, maximally some of the multitude of possible versions of well-regulated systems. (Because all ideals cannot exist concurrently.) Our neurology makes use of the unattainable theoretical best regulated assembly, which is in all aspects optimally ordered, (but, alas, the costs of so many alternatives now being much less well-regulated outweigh the benefit of one of the strategies of the game becoming maximally well regulated). We have the **Gestalt** as a reference multitude, generated by a theoretical coincidence of many ideal, maximally usual, values, which necessarily exists also as an a priori mathematical fact, since we see it in Nature, outside of our brain too, in the form of **archetypical collections of most usual coincidences**, operationalized as schemata. [9]

8.5. Logical compromises and breakdowns foretold

Formal logic has a fabulous aversion to contradictions, like vampires to garlic. Logic, as a linear science, in the sense of $a=a$, is indeed unable to deal with the contradiction $pos((1,3),16,[ab]) = 3 \leftrightarrow pos((1,3),16,[ba]) = 4$.

Planar geometry makes a logical compromise possible. By drawing a plane with axes x,y : $[ab],[ba]$, we can point to the place of a point at the coordinates $x=3$, $y=4$. The members of a cycle during a reorder share a part of the relief, rewards of avoiding a logical contradiction. There is a lien, bondage that connects the members of a cycle.

In the idealized subjects: memory, genetics spoken about in the present treatise, the circumstances are optimal, cycles run concurrently and give rise by their interference patterns to new cycles and further predictable periodicities. The concepts of breakdown, dropout, hijack as solutions to avoid, escape, circumnavigate, compromise away logical contradictions are not necessary in ideal circumstances, in the sense of disturbances. Nature makes, however, use of **planned breakdowns**, too. The breakdowns are local, because although they cause the discontinuation of the reorder that was taking place, the local breakdown discontinues the process only in the context of the specific cycle of the reorder in which they respectively take place. (Remark: The proverb: *one swallow doesn't make summer* points out that Summer will inevitably come, even if the process contains the planned breakdown of swallows having come too early.)

We see Nature's creativity in organizing patterns of breakdowns. Each burst of a ganglion is concurrently a local breakdown in that ganglion. Some basic biophysical procedures have reached a limit and the process (of say, flooding the ganglion with nutrient X) cannot continue. The result is an electric burst. Our thinking is based on electrical discharges. Each discharge stands at the end of a period of logical compromises among cycles that run concurrently. If the geometrical implications of the cycles that have run so far concurrently, become insurmountably different, the system breaks down and emits an electrical discharge. Our thoughts are basically a statistic on deviations from routine in the frequency of planned, routine maintenance breakdown events. Nature employs virtuoso techniques to establish neural feedback loops: she drives a process to its extreme and that leads to a breakdown. Nature does not use brakes; she recycles the wrack. What patterns of breakdowns are produced out of the ordinary when confronted with Impression A is a description of Impression A (which may well be connected later to the memory content of an

Object A). We use logical contradictions as the basic symbols of state report feedback messages within our own neurology. The patterns of thoughts are based on patterns of breakdowns in local processes.

8.6. Closing words

Thank you for working your way through this educational manual. The author sincerely hopes that the work ferments the reader’s thinking. As Wittgenstein said, the system of thoughts presented here is useful but as a tool, and after one has finished using it, like a ladder climbed, it loses its relevance. Please forgive for the outer appearance of the tool, its core truth is beyond questions of presentation styles. May the natural numbers guide you in creating and developing, furnishing, and using a world view which is based on **implications of aspects of order**. One will not lose a bet on the idea that sorting and ordering elementary logical tokens will invariably turn up typical patterns, and that such, organically grown, archaic-classical patterns will be of interest for Theoretical Physics, Chemistry, Biology, Information Theory and maybe some other fields, too.

Annex

Exercise on reordering books, a random collection:

Table A.1: Example of a collection of experimental objects

Author	Title	Library key
Goethe	Faust	gF
Marx	Kapital	mK
Homer	Ilias	hl
Joyce	Ulysses	jU
Eddington	Constants	eC
Ehrenfels	Perception	eP
Freud	Dreams	fD
Aristoteles	Philosophy	aP
Plato	Philosophy	pP
Eddinton	Numbers	eN
Freud	Jokes	fJ
Euler	Numbers	eN

We shall **order** the books, first on Authors. For ease of presentation, we use the Library keys as abbreviations.

aP	eC	eN	eN	eP	fD	fJ	gF	hl	jU	mK	pP
----	----	----	----	----	----	----	----	----	----	----	----

Table A.2. Experimental objects sorted on first argument

1	2	3	4	5	6	7	8	9	10	11	12
---	---	---	---	---	---	---	---	---	----	----	----

Table A.3: Linear number of experimental objects

eC	fD	gF	hl	fJ	mK	eN	eN	aP	eP	pP	jU
----	----	----	----	----	----	----	----	----	----	----	----

Table A.4: Experimental objects sorted on second argument

We have now established two different sequences, both are valid for the same collection of objects. Presently, the books are enumerated while in a sequence sorted on the first argument.

We shall now proceed to the procedure of reordering the books, which we want being sequenced on the second argument. We shall draw arrows on steps of the reorder.

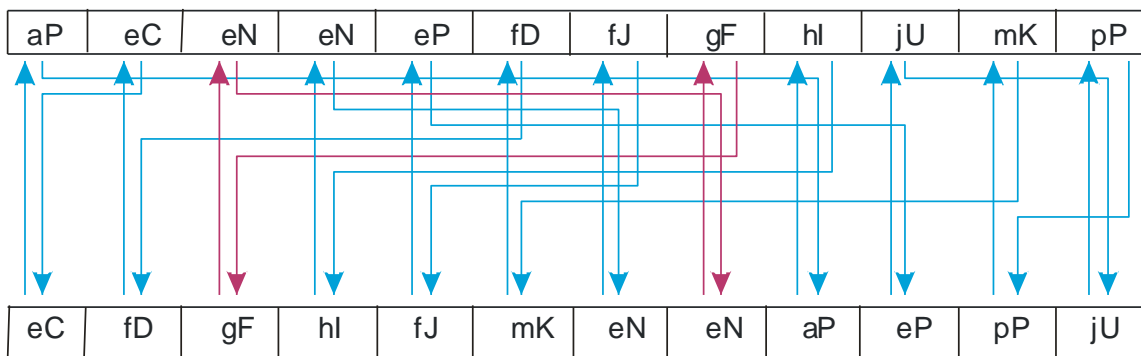

In this example, we see 2 cycles. Each cycle contains elements that are being replaced by their successor and are replacing their predecessor.

References

1. Wittgenstein, L.: Tractatus logico-philosophicus. Kegan Paul, London, (1922). also: <https://people.umass.edu/klement/tlp/>, last accessed 2021/12/11
2. Abundis, M.: Informatic Primitives: Logical vs. Material. In: <http://listas.unizar.es/pipermail/fis/2020-July/002595.html>, last accessed 2021/12/11
3. Reps, P.: Zen Flesh Zen Bones, Penguin
4. www.oeis.org/A242615, last accessed 2021/12/11
5. www.oeis.org/A000041, last accessed 2021/12/11
6. Whittaker, Edmund. “Eddington’s Theory of the Constants of Nature.” The Mathematical Gazette, vol. 29, no. 286, Mathematical Association, 1945, pp. 137–44, <https://doi.org/10.2307/3609461>.
7. www.oeis.org/A000142
8. www.oeis.org/A000142, last accessed 2021/12/11
9. Jung, C. G., Die Archetypen und das kollektive Unbewusste, Gesammelte Werke, Band 9, ISBN 978-3-8436-0127-6, Last accessed 2022/11/05
10. Rohracher, H.: Einfuehrung in die Psychologie, Urban & Schwarzenberg, Wien, 1963
11. Kant, I.: Prolegomena to Any Future Metaphysics, § 52c, Translated by Paul Carus, www.gutenberg.org, EBook #52821
12. St Thomas Aquinas, Summa Theologiae, Whether truth resides only in the intellect, IntraText Edition, ASIN 0870610635
13. Wittgenstein, L.: op.cit., Introduction, § # 5
14. Bruno, G.: De la causa, principio, et uno, 1584, ISBN 1500842672

Authors' Information



Karl Javorszky: *clinical psychologist; retired.* Loeblichgasse 13/16, A-1090 Wien, e-mail: karl.javorszky@gmail.com

Scientific Interest: *Memory, How registering and reconstructing information is actually done, as a task of accounting and data processing.*